



НАРОДНАЯ УКРАИНСКАЯ АКАДЕМИЯ

**ПРАКТИКУМ ПО ПОДГОТОВКЕ
К ВНЕШНЕМУ
НЕЗАВИСИМОМУ ОЦЕНИВАНИЮ
ПО АНГЛИЙСКОМУ ЯЗЫКУ**

АУДИРОВАНИЕ

Для слушателей факультета
довузовской подготовки

Издательство НУА

НАРОДНАЯ УКРАИНСКАЯ АКАДЕМИЯ

**ПРАКТИКУМ ПО ПОДГОТОВКЕ
К ВНЕШНЕМУ
НЕЗАВИСИМОМУ ОЦЕНИВАНИЮ
ПО АНГЛИЙСКОМУ ЯЗЫКУ**

АУДИРОВАНИЕ

Для слушателей факультета
довузовской подготовки

Харьков
Издательство НУА
2018

УДК 81.111-028.17 (079)

ББК 81.432.1-9

П 69

*Утверждено на заседании
кафедры германской и романской филологии
Народной украинской академии
Протокол № 2 от 03.09.2018*

Составители *В. В. Ильченко, Е. В. Карпенко*

Рецензент проф. *Змиева И. В.*

Практикум містить завдання з англійської мови частині «Аудіювання» у форматі ЗНО і призначений для формування і закріплення навичок, необхідних для складання ЗНО.

П69 Практикум по подготовке к внешнему независимому оцениванию по английскому языку. Аудирование : для слушателей ф-та довузовской подготовки / В. В. Ильченко, Е. В. Карпенко / Нар. укр. акад., [каф. герман. и роман. филол. ; сост.: В. В. Ильченко, Е. В. Карпенко]. – Харьков : Изд-во НУА, 2018. – 100 с.

Практикум содержит задания по английскому языку части «Аудирование» в формате ВНО и предназначен для формирования и закрепления навыков, необходимых для сдачи ВНО.

УДК 81.111-028.17 (079)

ББК 81.432.1-9

CONTENTS

Алгоритм выполнения заданий	4
Test 1	12
Test 2	15
Test 3	18
Test 4	21
Test 5	24
Test 6	27
Test 7	30
Test 8	33
Test 9	36
Test 10	39
Test 11	42
Test 12	45
Test 13	48
Test 14	51
Test 15	54
Test 16	57
Test 17	60
Test 18	63
Test 19	66
Test 20	69
Test 21	72
Test 22	75
Test 23	78
Test 24	81
Бланки ответов	85

АЛГОРИТМ ВЫПОЛНЕНИЯ ЗАДАНИЙ

Task 1

Listen to the speakers. For questions (1–6) choose the correct answer (A, B or C). Write your answers on the separate answer sheet. You will listen to each recording twice.

1 Where did the man leave his camera?

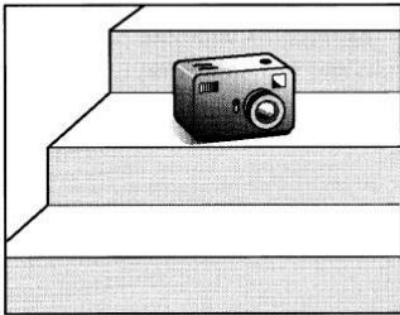

A

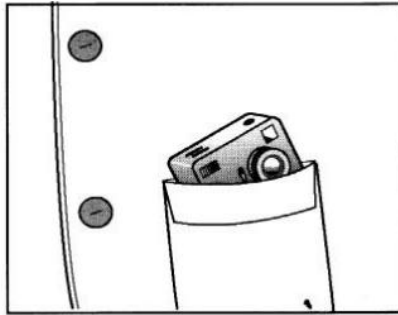

B

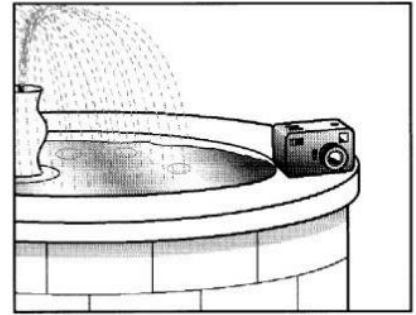

C

2 What CAN'T the woman find?

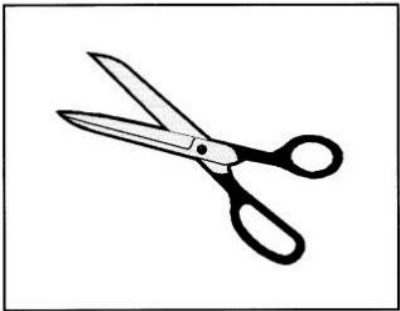

A

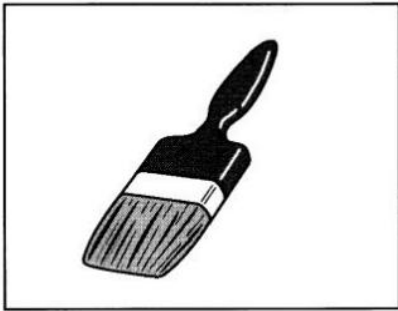

B

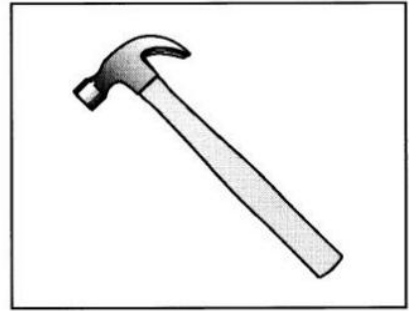

C

3 What time did the girl arrive?

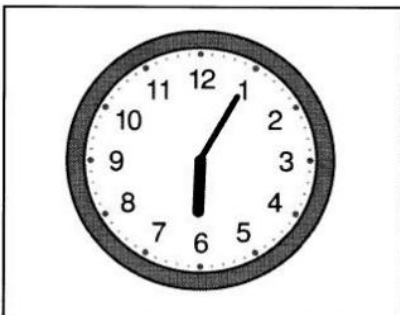

A

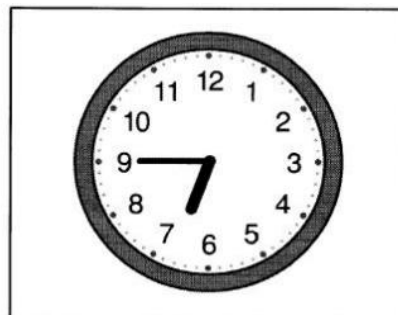

B

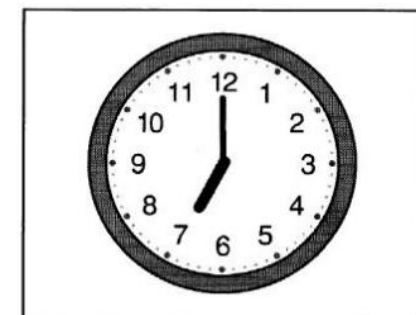

C

АЛГОРИТМ ВЫПОЛНЕНИЯ ЗАДАНИЯ 1 ВОПРОСЫ 1–3

- 1) Изучите инструкцию к заданию.
- 2) До первого прослушивания аудиотекста изучите вопрос к заданию.
- 3) Найдите в вопросе ключевые слова, которые помогут вам определить, какого рода информация потребуется для выбора правильного ответа.
 - 1 **Where** did the man **leave** his **camera**?
 - 2 What **CAN'T** the woman **find**?
 - 3 **What time** did the girl **arrive**?
- 4) Внимательно изучите картинки и определите возможную тематику аудиотекста.

1

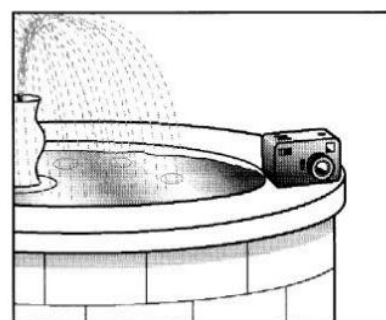
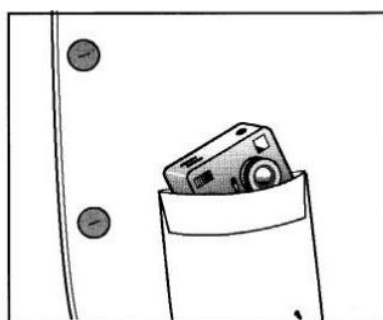
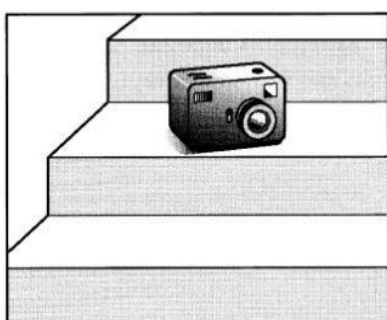

(местонахождение фотоаппарата)

2

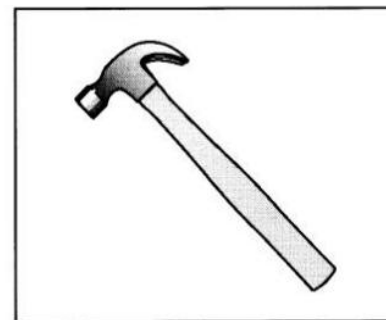
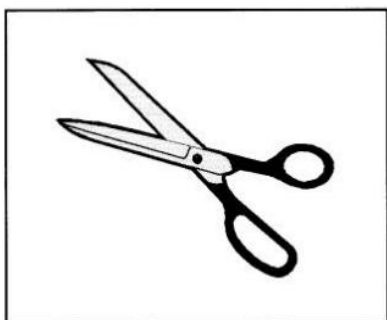

(название инструмента)

3

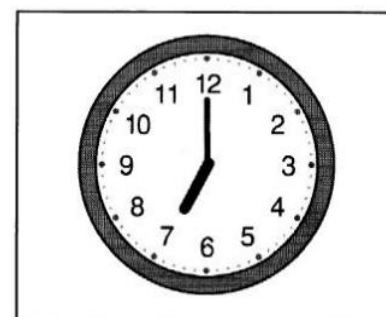
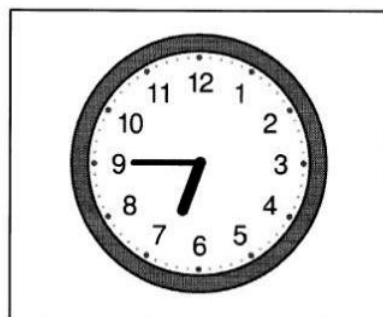
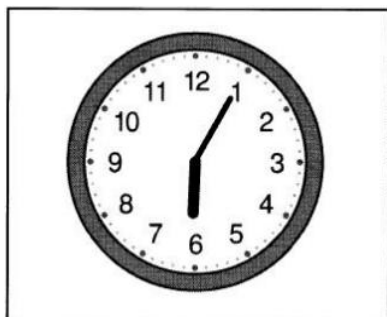

(время совершения действия)

- 5) Во время первого прослушивания попытайтесь соотнести ключевые слова в вопросе с информацией в аудиотексте и определить правильный вариант ответа.

1 **Man:** Oh no! I haven't got my **camera!**
Woman: But you used it just now *to take a photograph of the fountain.*
Man: Oh I remember, I *put it down on the steps* while I put my coat on.
Woman: Well, let's drive back quickly – it might still be there.

Правильный вариант – картинка А.

2 **Woman:** I'm going to mend and paint the shelves in your bedroom today.
Man: Great, mum. Anything I can do to help?
Woman: Yes, can you *go to the shop and get me a new paint brush* – this one's too old. But before you do that, ask your father what he's done with **the hammer** – *I've looked everywhere for it*. There was nothing in the toolbox except **this pair of scissors** which I *lost months ago!*

Правильный вариант – картинка С.

3 **Man:** Sorry I'm late – have you been here long?
Woman: Well... not really, about five or ten minutes perhaps. I *left home at five past six* and *got here at exactly quarter to seven.*

Правильный вариант – картинка В.

Man: Well... if we hurry, we'll still make it for the beginning of the film at seven.

- 6) Во время второго прослушивания проверьте правильность ответа.

ВОПРОСЫ 4–6

4 **What does the woman's house look like now?**

- A It has a garden and a hedge in front.
- B It has an additional bedroom over the garage.
- C It has a car park in front.

5 **What has the boy lost?**

- A a camera
- B a map
- C money

6 **What musical instruments does the family have now?**

- A a piano and a guitar
- B drums and a guitar
- C a piano and a flute

- 1) Изучите инструкцию к заданию.
- 2) До первого прослушивания аудиотекста изучите вопрос к заданию.
- 3) Найдите в вопросе ключевые слова, которые помогут вам определить, какого рода информация потребуется для выбора правильного ответа.
 - 4 What does the woman's **house look like now**?
 - 5 What has **the boy lost**?
 - 6 What **musical instruments** does **the family have now**?
- 4) Внимательно изучите варианты ответов и, если необходимо, определите ключевые слова.
 - 4 A It has **a garden and a hedge in front**.
B It has **an additional bedroom over the garage**.
C It has **a car park in front**.
 - 5 A **a camera**
B **a map**
C **money**
 - 6 A **a piano and a guitar**
B **drums and a guitar**
C **a piano and a flute**
- 5) Во время первого прослушивания попытайтесь соотнести ключевые слова в вопросе и вариантах ответов с информацией в аудиотексте и определить правильный вариант ответа.

- 4 What does the woman's **house look like now**?
 - A It has **a garden and a hedge in front**.
 - B It has **an additional bedroom over the garage**.
 - C It has **a car park in front**.

Правильный вариант – B.

Woman: It was really strange going back to Redmond, where I used to live.

Everything has changed so much. I went to see my old house. It *used to have trees in the garden and a hedge in the front*. Well, the people who own it now *have built another bedroom over the top of the garage*, and *removed the trees and the hedge* so they *have more room to park their cars*. It made me feel really sad, because it looked so different.

- 5 What has **the boy lost**?
 - A **a camera**
 - B **a map**
 - C **money**

Правильный вариант – A.

Boy: Mum – I love it here. The city's really interesting and it's quite easy to find my way round, thanks to **the map** you gave me – I don't know *what I'd do without it*. I've taken some great photos, but I *left my camera on a tram* so I won't be able to show you! And things are more expensive than I expected, so I don't think my **money will last very long**. Can you send me some more? Thanks. Speak to you again soon.

6 What **musical instruments** does **the family** have now?

A a **piano** and a **guitar**

B **drums** and a **guitar**

C a **piano** and a **flute**

Правильный
вариант – А.

Woman: Does Marianne still play **the piano**?

Man: Yes, she's got it in her room. It's Bob I'm worried about, he really

wants to play **the drums**. If he wants to be a pop star **the guitar** would be OK, but we've said drums are just too noisy. And to think we spent all that money on a **flute** and he's hardly used it.

6) Во время второго прослушивания проверьте правильность ответа.

Task 2

Listen to the text. For statements (7–11) choose T if the statement is true, F if it is false according to the text. Write your answers on the separate answer sheet. You will listen to the text twice.

		T	F
7	This will be the Sanchez family's first trip to England.	<input type="checkbox"/>	<input type="checkbox"/>
8	Michael suggests sightseeing in London.	<input type="checkbox"/>	<input type="checkbox"/>
9	The Sanchez children are teenagers.	<input type="checkbox"/>	<input type="checkbox"/>
10	Jane has been to the car museum.	<input type="checkbox"/>	<input type="checkbox"/>
11	Jane and Michael have bought tickets for the tennis competition.	<input type="checkbox"/>	<input type="checkbox"/>

АЛГОРИТМ ВЫПОЛНЕНИЯ ЗАДАНИЯ 2

- 1) Изучите инструкцию к заданию.
- 2) До первого прослушивания аудиотекста изучите письменные утверждения 7–11, но не пытайтесь определить правильный ответ.
- 3) В прочитанных утверждениях выделите ключевые слова, которые помогут определить, какая информация вам может понадобиться для того, чтобы решить, является ли данное утверждение верным (T) или неверным (F).

7 This will be the Sanchez family's **first trip to England**. (*были ли в Англии раньше*)

8 **Michael** suggests **sightseeing in London**. (*кто предлагает осмотр достопримечательностей Лондона/какую форму досуга предлагает Майкл*)

9 The Sanchez **children** are **teenagers**. (*возраст детей*)

10 **Jane** has been to **the car museum**. (*посещала ли Джейн музей автомобилей*)

11 Jane and Michael have bought **tickets** for **the tennis competition**.

(кто купил билеты на соревнование по теннису/куплены или нет билеты на соревнование по теннису/куда куплены билеты)

- 4) Во время первого прослушивания попытайтесь соотнести ключевые слова и фразы в письменные утверждения 7–11 с информацией в аудиотексте и определить утверждения как верные (T) или неверные (F).

Утверждение 7 – This will be the Sanchez family’s **first trip to England**.

Jane: ... Anyway, they’re coming to stay next month.

They haven’t been to England before, so Mum wants us to help plan a really good week for them.

Правильный вариант – T.

Утверждение 8 – **Michael** suggests **sightseeing in London**.

Michael: Well, they must **spend a day in London**

seeing the famous places like Buckingham Palace and the Tower of London.

Правильный вариант – T.

Утверждение 9 – The Sanchez **children** are **teenagers**.

Michael: How old are they?

Jane: One’s **12** and the other’s **nine**.

Правильный вариант – F.

Утверждение 10 – **Jane** has been to **the car museum**.

Jane: Oh no, I found that car museum so boring.

I don’t think any of them would like that.

Правильный вариант – T.

Утверждение 11 – **Jane and Michael** have bought **tickets** for **the tennis competition**.

Michael: Fine. And what about tennis? Do you think **we could still get tickets** for the Open Tennis competition in Bournemouth?

Jane: I’m sure **we could**...

Правильный вариант – F.

- 5) Во время второго прослушивания проверяем ответы и восполняем недостающие.

Task 3

Listen to the text. For questions (12–16) choose the correct answer (A, B or C). Write your answers on the separate answer sheet. You will listen to the text twice.

12 How well did the speaker do at school?

A He was an average student.

B His parents helped him.

C He had problems passing exams.

- 13 What did he do when he left school?**
A He got a part-time job.
B He did a business course.
C He went to art college.
- 14 When did he go to London?**
A at the age of seventeen
B as soon as he had enough money
C when he won a prize
- 15 How long did he stay in Milan?**
A three months
B nine months
C three years
- 16 Why did he have difficulties in New York?**
A He wanted to be nearer his home.
B He could not start a company there.
C The work was more stressful than he had expected.

АЛГОРИТМ ВЫПОЛНЕНИЯ ЗАДАНИЯ 3

- 1) Изучите инструкцию к заданию.
- 2) До первого прослушивания аудиотекста изучите все тестовые вопросы к заданию.
- 3) Найдите в вопросах ключевые слова, которые помогут вам определить, какого рода информация потребуется для выбора правильного ответа.
12 How well did the speaker do at school?
13 What did he do when he left school?
14 When did he go to London?
15 How long did he stay in Milan?
16 Why did he have difficulties in New York?
- 4) При первом прослушивании отмечайте разными символами ответы, которые вы считаете правильными, и те, в которых вы не уверены.

12 How well did the speaker do at school?

- A** He was an average student.
B His parents helped him.
C He had problems passing exams.

<i>Правильный вариант – А.</i>

Speaker: I wasn't bad at school, I mean I **was a typical student**, passed enough exams and so on, and they could understand I might want to go to art college, but fashion just wasn't a serious subject for them.

13 What did he **do when he left school**?

- A He got a part-time job.
- B He did a business course.
- C He went to art college.

Правильный вариант – В.

Speaker: Anyway, they said **I had to do a year's business course first**. I didn't like it at the time, but later, it made a big difference to me.

14 **When did he go to London?**

- A at the age of seventeen
- B after two years at art college
- C when he won a prize

Правильный вариант – С.

Speaker: Then I did two years at the local art college. I wanted to go to London straight away, but my parents insisted. I think they thought I was too young, I was still only seventeen by then, but in the end it was cost. London is a very expensive place for a student. So **I stayed at home until I won a prize** for a design which actually gave me a place at a London college for nine months.

15 **How long did he stay in Milan?**

- A three months
- B nine months
- C three years

Правильный вариант – С.

Speaker: There, I was able to make a lot of useful contacts - I was already working for an Italian fashion house three months before I left. I went on to **spend three wonderful years in Milan**, then I got the job in New York for a year...

16 **Why did he have difficulties in New York?**

- A He wanted to be nearer his home.
- B He could not start a company there.
- C The work was more stressful than he had expected.

Правильный вариант – С.

Speaker: ... then I got **the job in New York** for a year, which **was** really exciting, but **unbelievably stressful**. I think probably because I was too far away from my family, more than any actual problems with the work itself.

5) Во время второго прослушивания проверьте свои правильные ответы и восполните недостающие.

	A	B	C
1			
2			
3			
4			
5			
6			

	T	F
7		
8		
9		
10		
11		

	A	B	C
12			
13			
14			
15			
16			

ЧАСТИНА «РОЗУМІННЯ МОВИ НА СЛУХ» (АУДІЮВАННЯ)
LISTENING

TEST 1

Task 1

Listen to the speakers. For questions (1–6) choose the correct answer (A, B or C). Write your answers on the separate answer sheet. You will listen to each recording twice.

1 Where will the girls meet?

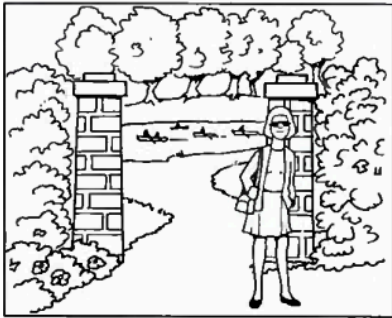

A

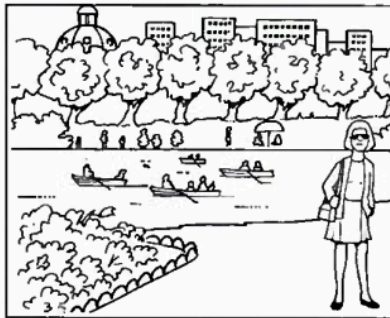

B

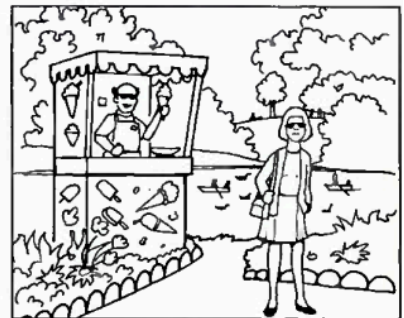

C

2 Which chair does the man want?



A



B



C

3 Which picture shows what the girls need?

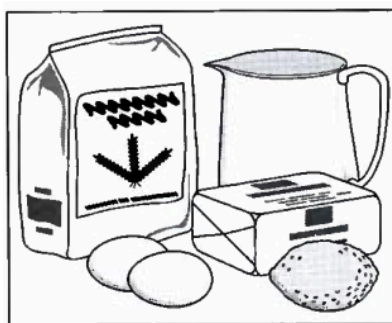

A

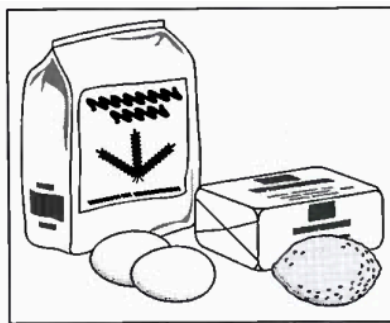

B

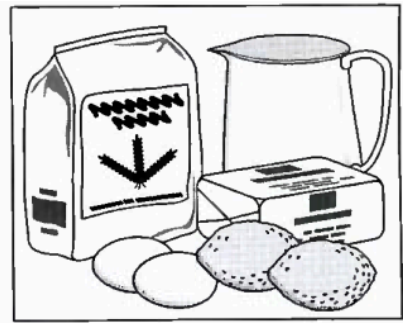

C

4 When and where are they meeting?

- A at half past seven in the restaurant
- B at seven in front of the restaurant
- C at six thirty near the restaurant

5 What will Chris get for his birthday?

- A CDs
- B a sweater
- C a sports manual

6 Where is he going to plant the tree?

- A behind the garage
- B by the front door
- C at the end of the lawn

Task 2

Listen to the text. For statements (7–11) choose T if the statement is true, F if it is false according to the text. Write your answers on the separate answer sheet. You will listen to the text twice.

- | | T | F |
|---|--------------------------|--------------------------|
| 7 Jim's bicycle needs to be mended. | <input type="checkbox"/> | <input type="checkbox"/> |
| 8 He's keen to start saving money. | <input type="checkbox"/> | <input type="checkbox"/> |
| 9 His mother thinks a mountain bike is suitable for their area. | <input type="checkbox"/> | <input type="checkbox"/> |
| 10 She encourages Jim to manage his money better. | <input type="checkbox"/> | <input type="checkbox"/> |
| 11 Jim is disappointed by his mother's suggestion. | <input type="checkbox"/> | <input type="checkbox"/> |

Task 3

Listen to the text. For questions (12–16) choose the correct answer (A, B or C). Write your answers on the separate answer sheet. You will listen to the text twice.

12 Where did the person who wrote the music live?

- A Italy
- B Spain
- C France

13 What else shares the title of this music?

- A a garden
- B a play
- C a park

14 What did people do when they first heard the music?

- A Some left before the end.
- B Only a few clapped.
- C Some asked for their money back.

15 How has this piece of music been used?

- A It has been played in the cinema.
- B It has been used in advertising.
- C It has been used for a TV play.

16 What number should you ring if you know the competition answer?

- A 0108 937 224
- B 0018 739 242
- C 0018 937 224

TEST 2

Task 1

Listen to the speakers. For questions (1–6) choose the correct answer (A, B or C). Write your answers on the separate answer sheet. You will listen to each recording twice.

1 Which picture shows what happened?



A



B



C

2 What is Sarah's mother doing?



A



B



C

3 What luggage is the man taking on holiday?

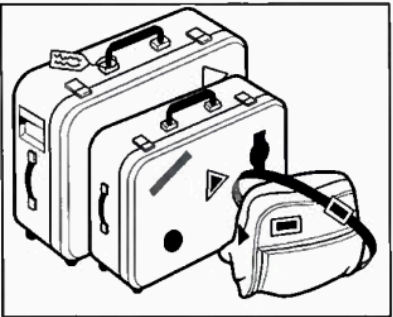

A

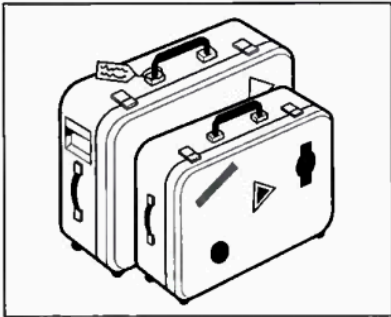

B

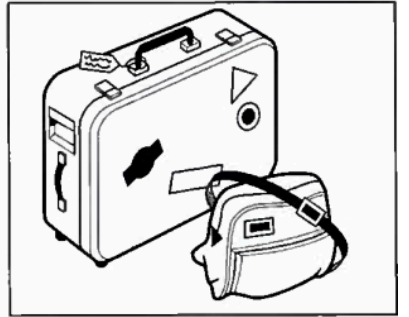

C

- 4 What is the man going to buy?**
A grapes and oranges
B bananas and oranges
C bananas only
- 5 What will the man and woman do on Sunday?**
A have a picnic
B do the housework
C watch a movie
- 6 Which hotel has the man chosen?**
A a large hotel at the seaside
B a large hotel in the centre of the city
C a large hotel at the seaside with a pool

Task 2

Listen to the text. For statements (7-11) choose T if the statement is true, F if it is false according to the text. Write your answers on the separate answer sheet. You will listen to the text twice.

- | | T | F |
|--|--------------------------|--------------------------|
| 7 Kate has stopped taking her medicine. | <input type="checkbox"/> | <input type="checkbox"/> |
| 8 Kate had an accident on her bike last week. | <input type="checkbox"/> | <input type="checkbox"/> |
| 9 George thinks Mr Gray is a lazy lecturer. | <input type="checkbox"/> | <input type="checkbox"/> |
| 10 Kate will miss three lectures. | <input type="checkbox"/> | <input type="checkbox"/> |
| 11 Kate wants to stay at home at the weekend. | <input type="checkbox"/> | <input type="checkbox"/> |

Task 3

Listen to the text. For questions (12-16) choose the correct answer (A, B or C). Write your answers on the separate answer sheet. You will listen to the text twice.

- 12 What is on at the Theatre Royal on 19 May?**
A jazz
B opera
C classical music
- 13 What do they sell during lunchtime jazz concerts at the Corn Exchange?**
A soft drinks and sandwiches
B wine and sandwiches
C soft drinks and light meals

- 14 What is on at the cathedral?**
A music
B poetry
C films
- 15 What does the festival programme offer at Ickworth?**
A a walk and a book reading
B a concert and a meal
C a walk and a concert
- 16 What booking CAN'T be made with a credit card?**
A a booking by post
B a booking by fax
C a booking by telephone

TEST 3

Task 1

Listen to the speakers. For questions (1 - 6) choose the correct answer (A, B or C). Write your answers on the separate answer sheet. You will listen to each recording twice.

1 Where is the station?

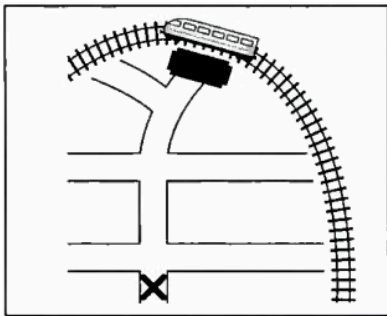

A

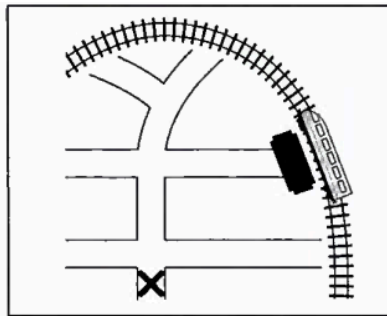

B

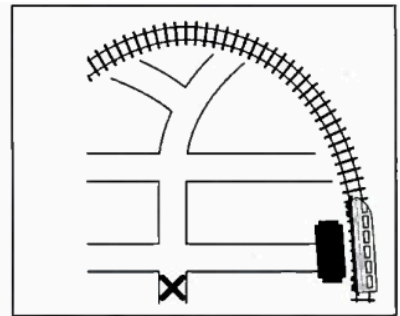

C

2 Where did the woman put the calculator?

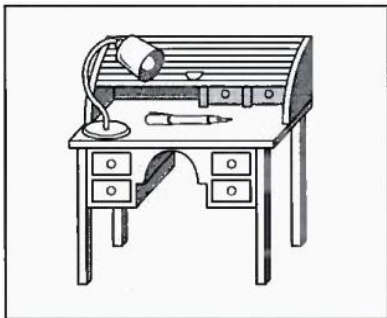

A

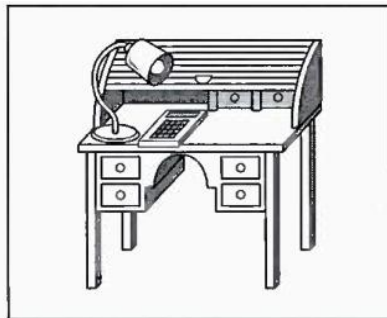

B

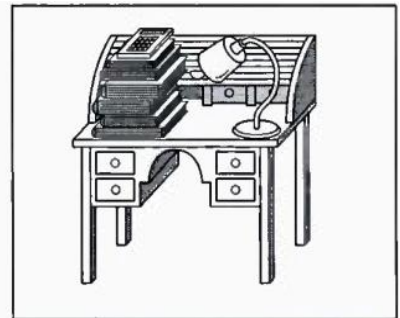

C

3 Where is Helen?



A

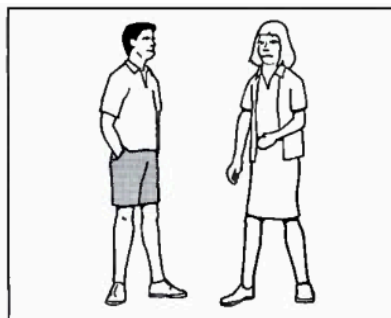

B

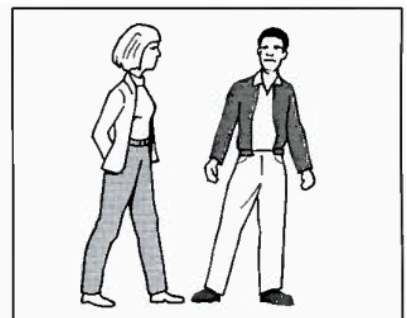

C

- 4 Which building was hit by lightning?**
 A the hotel
 B the factory
 C the church
- 5 What does the woman want to buy?**
 A boots
 B high-heeled shoes
 C flat shoes
- 6 Which picture does the woman decide to send?**
 A with the man standing in front of it
 B with the children playing in the back yard
 C with the children playing in front of it

Task 2

Listen to the text. For statements (7-11) choose T if the statement is true, F if it is false according to the text. Write your answers on the separate answer sheet. You will listen to the text twice.

- | | T | F |
|--|--------------------------|--------------------------|
| 7 Sonia would like a car for her birthday. | <input type="checkbox"/> | <input type="checkbox"/> |
| 8 Sonia's friend Maria has her own car. | <input type="checkbox"/> | <input type="checkbox"/> |
| 9 Sonia offers to get a job at weekends. | <input type="checkbox"/> | <input type="checkbox"/> |
| 10 Sonia's father understands how his daughter feels. | <input type="checkbox"/> | <input type="checkbox"/> |
| 11 Sonia suggests cooking a meal on her birthday. | <input type="checkbox"/> | <input type="checkbox"/> |

Task 3

Listen to the text. For questions (12-16) choose the correct answer (A, B or C). Write your answers on the separate answer sheet. You will listen to the text twice.

- 12 What is required to apply for the Camp?**
 A to be a student
 B to be at least twenty-four years old
 C to speak more than one language
- 13 What can be expected of you in a Camp tent?**
 A to mix with other nationalities
 B to share with five other people
 C to know the other people

14 What kind of people does the Camp want?

- A those who are good at cooking
- B those who are good organisers
- C those who are able to mix well

15 What is expected of a Camp member?

- A to be a good singer
- B to join in performances
- C to be good at acting

16 What are the Camp fees requirements?

- A must be paid in dollars
- B must be paid by cheque
- C must be paid before the Camp starts

TEST 4

Task 1

Listen to the speakers. For questions (1 - 6) choose the correct answer (A, B or C). Write your answers on the separate answer sheet. You will listen to each recording twice.

1 What did she bring?

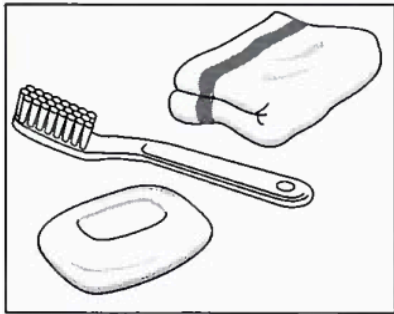

A

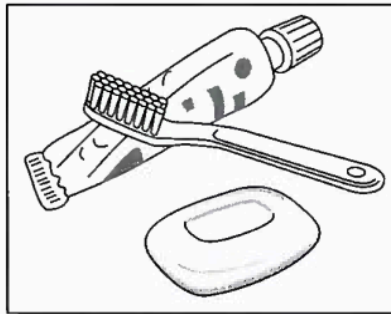

B

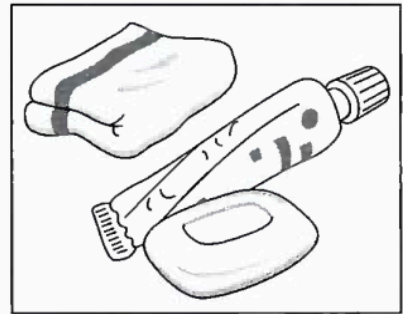

C

2 Which pianist are the two people talking about?



A



B



C

3 What damage was done to the car?

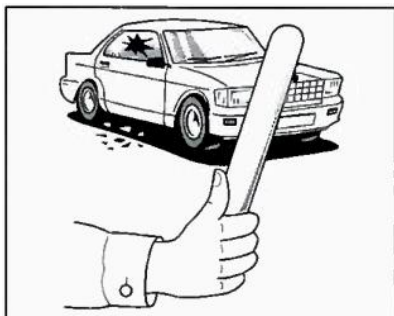

A

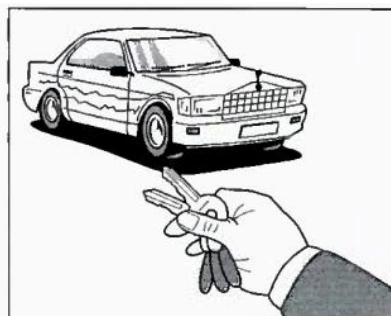

B

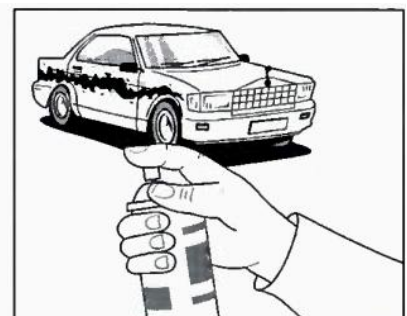

C

- 4 Where are the woman's glasses?**
A on her nose
B on the TV-set
C at her working place
- 5 What did Sally buy?**
A a skirt and a pair of jeans
B a T-shirt and shoes
C a T-shirt and a pair of jeans
- 6 Where are the man and his grandma?**
A at the station
B at the airport
C in the car

Task 2

Listen to the text. For statements (7-11) choose T if the statement is true, F if it is false according to the text. Write your answers on the separate answer sheet. You will listen to the text twice.

- | | T | F |
|--|--------------------------|--------------------------|
| 7 The man wants to spend the evening at home. | <input type="checkbox"/> | <input type="checkbox"/> |
| 8 The woman suggests they hire a video. | <input type="checkbox"/> | <input type="checkbox"/> |
| 9 They both want to see something light. | <input type="checkbox"/> | <input type="checkbox"/> |
| 10 The woman only likes to see a film once. | <input type="checkbox"/> | <input type="checkbox"/> |
| 11 In the end they decide to watch a video. | <input type="checkbox"/> | <input type="checkbox"/> |

Task 3

Listen to the text. For questions (12-16) choose the correct answer (A, B or C). Write your answers on the separate answer sheet. You will listen to the text twice.

- 12 According to the speaker, who is interested in fashion nowadays?**
A rich people.
B young people.
C most people.
- 13 Which of the following is NOT TRUE about fashion clothes made before the 1900s?**
A were individually made
B were copied from magazines
C were very expensive

14 Which of the following is TRUE about Coco Chanel?

- A was born in 1908
- B changed people's ideas about fashion
- C liked wearing tight-fitting clothes

15 What happened in the 1920s?

- A White skirts became fashionable.
- B Clothes started to cost less.
- C Women took up sports.

16 What is the exhibition devoted to?

- A clothes that are very old
- B fashion for the future
- C pictures of today's fashions

TEST 5

Task 1

Listen to the speakers. For questions (1 - 6) choose the correct answer (A, B or C). Write your answers on the separate answer sheet. You will listen to each recording twice.

1 Which film is the man talking about?

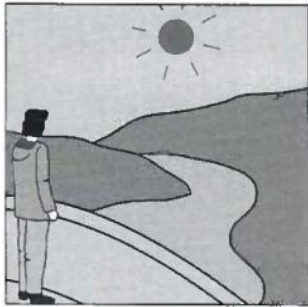

A

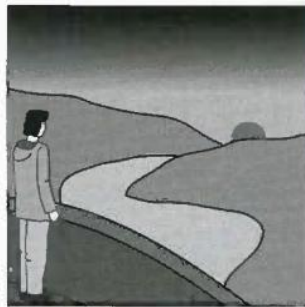

B

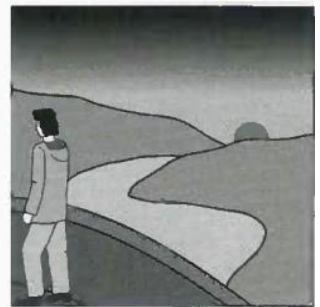

C

2 What should the woman do first?



A

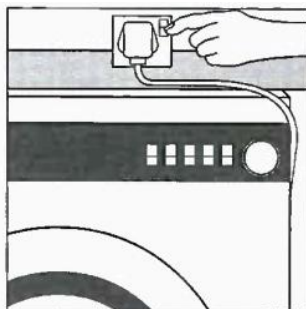

B



C

3 What is David going to do this weekend?



A

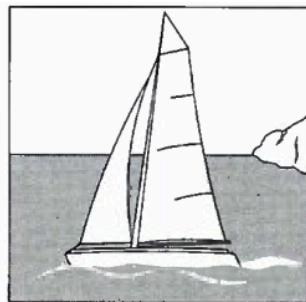

B



C

- 4 What was in the woman's bag?**
 A glasses and a purse
 B a purse and keys
 C glasses, a purse and keys
- 5 Which tie does the man choose?**
 A with squares on it
 B with dots on it
 C without any patterns
- 6 What time is the appointment?**
 A 11.15
 B 10.15
 C 13.55

Task 2

Listen to the text. For statements (7-11) choose T if the statement is true, F if it is false according to the text. Write your answers on the separate answer sheet. You will listen to the text twice.

- | | T | F |
|---|--------------------------|--------------------------|
| 7 They are going to have the practice outdoors today. | <input type="checkbox"/> | <input type="checkbox"/> |
| 8 Sam has decided he no longer wants to be Romeo. | <input type="checkbox"/> | <input type="checkbox"/> |
| 9 Alice agrees with Miss Hayes about Sam's voice. | <input type="checkbox"/> | <input type="checkbox"/> |
| 10 Alice persuades Sam to take a smaller part in the play. | <input type="checkbox"/> | <input type="checkbox"/> |
| 11 Someone is needed to produce the scenery. | <input type="checkbox"/> | <input type="checkbox"/> |

Task 3

Listen to the text. For questions (12-16) choose the correct answer (A, B or C). Write your answers on the separate answer sheet. You will listen to the text twice.

- 12 When is *the Railway Princess* on television?**
 A from 9.00 to 10.00
 B from 9.00 to 10.30
 C from 9.30 to 11.00
- 13 When is there a music programme for teenagers?**
 A early in the morning
 B before lunch
 C at lunchtime

- 14** What competition WON'T be broadcast if the weather is bad?
- A cycling
 - B skiing
 - C tennis
- 15** What do teams have to guess in the quiz programme?
- A the year
 - B the person
 - C the place
- 16** What kind of film is *I Could Live Forever*?
- A a comedy
 - B a musical
 - C a thriller

TEST 6

Task 1

Listen to the speakers. For questions (1 - 6) choose the correct answer (A, B or C). Write your answers on the separate answer sheet. You will listen to each recording twice.

1 How did the film end?



A



B



C

2 What time does the train to Rome leave?

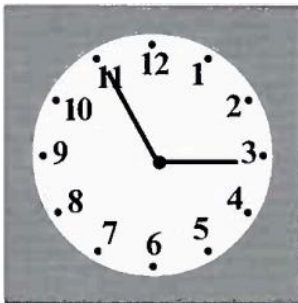

A



B

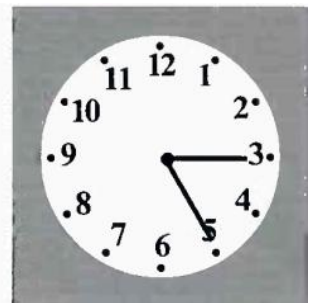

C

3 How were they told to do their homework?

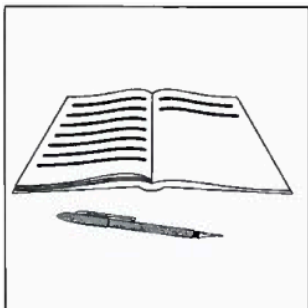

A

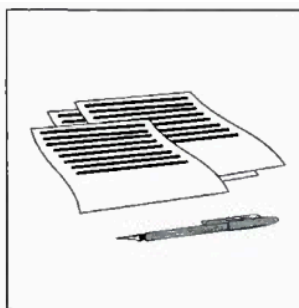

B

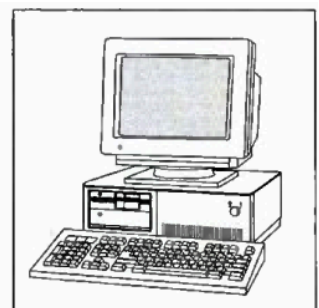

C

- 4 What is broken?**
A a plate
B a table
C a new lamp
- 5 Where are the man's shoes?**
A under the chair
B by the television
C by the door
- 6 What will Paul get at the shop?**
A one red pepper and mushrooms
B carrots and mushrooms
C one red pepper and carrots

Task 2

Listen to the text. For statements (7-11) choose T if the statement is true, F if it is false according to the text. Write your answers on the separate answer sheet. You will listen to the text twice.

- | | T | F |
|--|--------------------------|--------------------------|
| 7 Matthew had intended to catch the bus this morning. | <input type="checkbox"/> | <input type="checkbox"/> |
| 8 Matthew thought his mother knew he wanted the car this morning. | <input type="checkbox"/> | <input type="checkbox"/> |
| 9 Matthew is going to help Alan to repair his car. | <input type="checkbox"/> | <input type="checkbox"/> |
| 10 Matthew needs the car next Wednesday. | <input type="checkbox"/> | <input type="checkbox"/> |
| 11 Matthew's mother agrees she made a mistake. | <input type="checkbox"/> | <input type="checkbox"/> |

Task 3

Listen to the text. For questions (12-16) choose the correct answer (A, B or C). Write your answers on the separate answer sheet. You will listen to the text twice.

- 12 When did the shopping centre open?**
A three weeks ago
B two months ago
C three years ago
- 13 According to the speaker, what is the best way travel to Waterside?**
A by coach
B by car
C by train

- 14 What can you do on the third level?**
A get information
B watch a film
C find a bank
- 15 Apart from shopping, what else can you do at Waterside?**
A feed the ducks
B go swimming
C go sailing
- 16 What does the speaker complain about?**
A There was nowhere to put rubbish.
B The food in the cafe was disappointing.
C The service in the shops was slow.

TEST 7

Task 1

Listen to the speakers. For questions (1 - 6) choose the correct answer (A, B or C). Write your answers on the separate answer sheet. You will listen to each recording twice.

1 How did the woman get to work today?

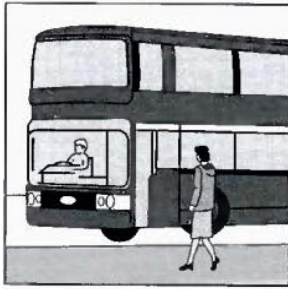

A



B

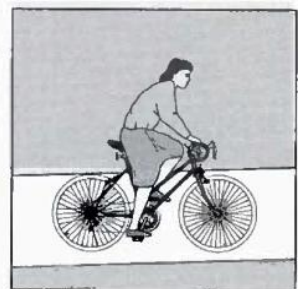

C

2 When must the boys get on the coach?

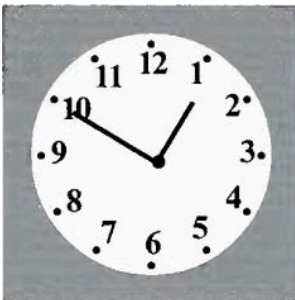

A

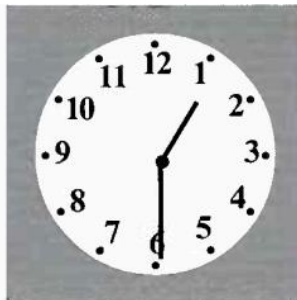

B

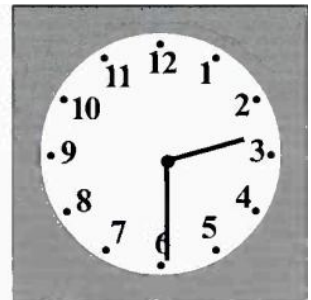

C

3 Where are the photographs?

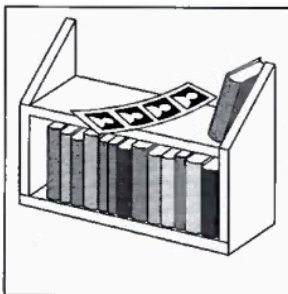

A

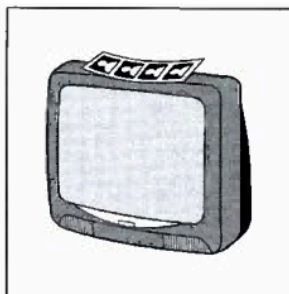

B

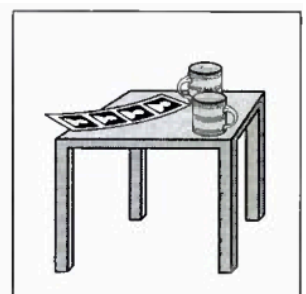

C

- 4 What fruit do they take?**
A oranges and grapes
B apples and grapes
C grapes and bananas
- 5 Which present has the man bought?**
A a book
B some flowers
C a pair of gloves
- 6 What did Ben break?**
A a cup and a plate
B two cups and some plates
C a cup and some plates

Task 2

Listen to the text. For statements (7-11) choose T if the statement is true, F if it is false according to the text. Write your answers on the separate answer sheet. You will listen to the text twice.

- | | T | F |
|---|--------------------------|--------------------------|
| 7 John hopes to keep his singing lessons a secret. | <input type="checkbox"/> | <input type="checkbox"/> |
| 8 John says he has had singing lessons before. | <input type="checkbox"/> | <input type="checkbox"/> |
| 9 John has always liked musical shows. | <input type="checkbox"/> | <input type="checkbox"/> |
| 10 John was pleased with the practice show. | <input type="checkbox"/> | <input type="checkbox"/> |
| 11 Louise would like to dance in a musical show. | <input type="checkbox"/> | <input type="checkbox"/> |

Task 3

Listen to the text. For questions (12-16) choose the correct answer (A, B or C). Write your answers on the separate answer sheet. You will listen to the text twice.

- 12 When does the concert start?**
A at 7 pm
B at 7.30 pm
C at 8.30 pm
- 13 What will the money from the concert pay for?**
A books for the school library
B some school sports equipment
C a school trip to London

- 14 Where will the Walking Club meet?**
A in the market square
B at the bus station
C in the car park by the lake
- 15 Where can you hear a talk by a writer?**
A in the library
B at the bookshop
C at the university
- 16 What is required to go to the talk?**
A to be a club member
B to be over 16
C to book a ticket

TEST 8

Task 1

Listen to the speakers. For questions (1 - 6) choose the correct answer (A, B or C). Write your answers on the separate answer sheet. You will listen to each recording twice.

1 How will they travel to Edinburgh?



A

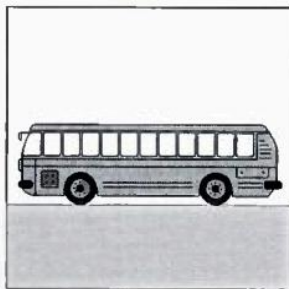

B

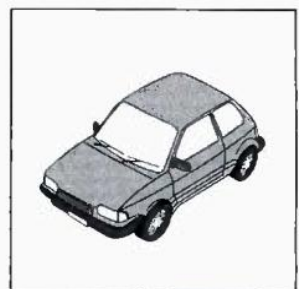

C

2 Which is the photo of the girl's father?

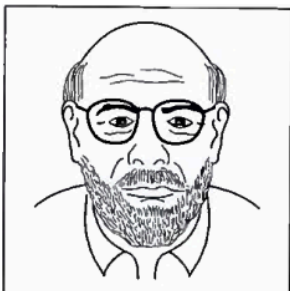

A



B



C

3 What must the woman wear at work?



A



B



C

- 4 Where will they sit in the theatre?**
A half way back from the stage
B near the stage
C half way back from the stage to one side
- 5 How did the woman cook the onions?**
A fried them
B boiled them
C baked them
- 6 What will the man buy?**
A a newspaper and a plant
B some flowers, chocolate and a card
C some flowers, a card and a newspaper

Task 2

Listen to the text. For statements (7-11) choose T if the statement is true, F if it is false according to the text. Write your answers on the separate answer sheet. You will listen to the text twice.

- | | T | F |
|---|--------------------------|--------------------------|
| 7 Mike likes to plan ahead more than Ann does. | <input type="checkbox"/> | <input type="checkbox"/> |
| 8 Ann thinks they should buy a useful present. | <input type="checkbox"/> | <input type="checkbox"/> |
| 9 Mike thinks he should choose the present. | <input type="checkbox"/> | <input type="checkbox"/> |
| 10 Mike has known Tony the longest. | <input type="checkbox"/> | <input type="checkbox"/> |
| 11 Mike thinks he will enjoy the wedding. | <input type="checkbox"/> | <input type="checkbox"/> |

Task 3

Listen to the text. For questions (12-16) choose the correct answer (A, B or C). Write your answers on the separate answer sheet. You will listen to the text twice.

- 12 What event can the tickets still be got for?**
A the piano concert
B Twelfth Night
C Spider and Rose
- 13 Why will the coach leave at 3.30?**
A because they don't want to miss the shows
B because they want free time at the Arts Centre
C because it's a long journey to the Arts Centre

- 14 You do not have to pay to see everything, EXCEPT**
A the Russian ballet exhibition.
B the Scottish jewellery.
C the South American photographs.
- 15 Where can you have a snack and a hot drink?**
A at the Fountain
B at Charlie's
C at the cinema kiosk
- 16 What time should everyone get back on the coach?**
A at 10.10
B at 10.15
C at 10.20

TEST 9

Task 1

Listen to the speakers. For questions (1 - 6) choose the correct answer (A, B or C). Write your answers on the separate answer sheet. You will listen to each recording twice.

1 Which is the woman's house?



A

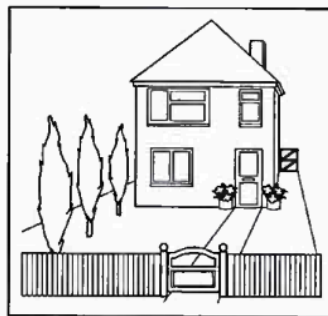

B



C

2 Why will drivers have problems this morning?

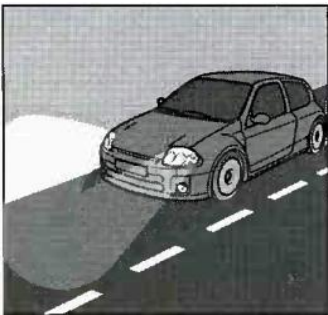

A

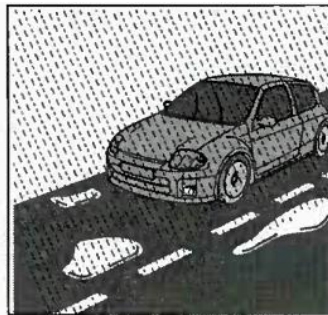

B

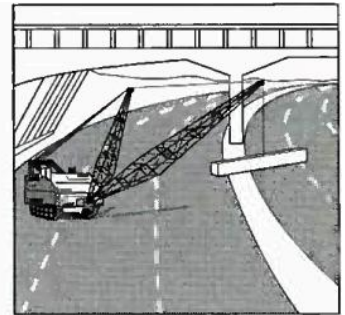

C

3 What has the woman just bought?

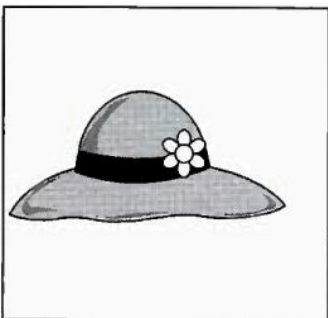

A



B



C

4 Which activity will the family do this year?

- A sailing
- B cycling
- C walking

5 What did Simon do this morning?

- A went shopping
- B cleaned the window
- C talked on the phone

6 What hasn't the girl packed yet?

- A a towel
- B a toothbrush
- C toothpaste

Task 2

Listen to the text. For statements (7-11) choose T if the statement is true, F if it is false according to the text. Write your answers on the separate answer sheet. You will listen to the text twice.

- | | T | F |
|--|--------------------------|--------------------------|
| 7 Clare thinks their father will be pleased by Tom's news. | <input type="checkbox"/> | <input type="checkbox"/> |
| 8 Tom believes he can manage both swimming and school work. | <input type="checkbox"/> | <input type="checkbox"/> |
| 9 Tom's teacher thinks Tom is clever. | <input type="checkbox"/> | <input type="checkbox"/> |
| 10 Tom dislikes doing maths. | <input type="checkbox"/> | <input type="checkbox"/> |
| 11 Clare thinks it is a bad idea to take a friend's advice. | <input type="checkbox"/> | <input type="checkbox"/> |

Task 3

Listen to the text. For questions (12-16) choose the correct answer (A, B or C). Write your answers on the separate answer sheet. You will listen to the text twice.

12 What was the main reason for Angela's trip?

- A to make money for her business
- B to make money for other people
- C to have an exciting adventure

13 What does Angela say about her life now?

- A She feels much older.
- B She likes to be active and busy.
- C She is lonely without her children.

14 What happened during Angela and her teacher's trip?

- A They did very little sightseeing.
- B They carried all the water they needed.
- C They had engine problems several times.

15 What did Angela enjoy most about the trip?

- A flying at night
- B walking in the desert
- C watching the changes in the scenery

16 What did Angela miss most while she was away?

- A modern bathrooms
- B regular exercise
- C interesting entertainment

TEST 10

Task 1

Listen to the speakers. For questions (1 - 6) choose the correct answer (A, B or C). Write your answers on the separate answer sheet. You will listen to each recording twice.

1 What will they have for lunch?

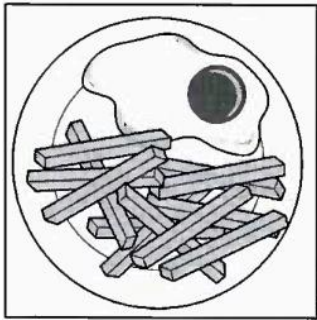

A



B

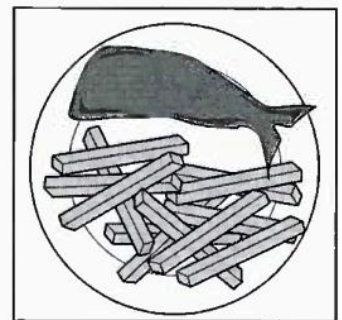

C

2 Why was the man late home?

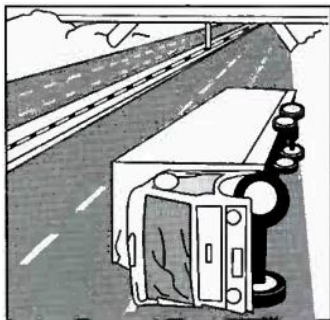

A

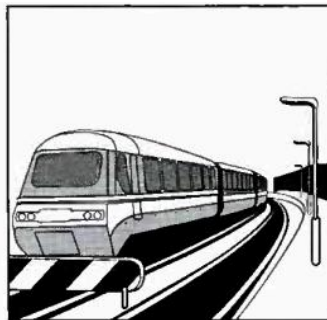

B

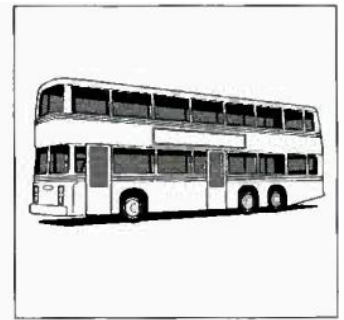

C

3 What time was the woman's appointment?

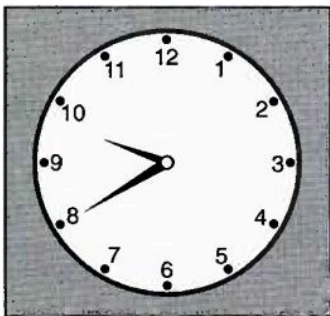

A

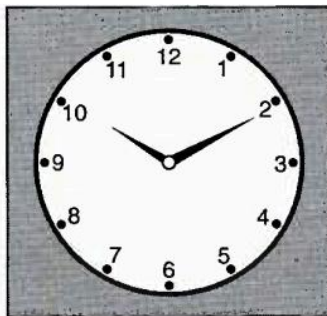

B

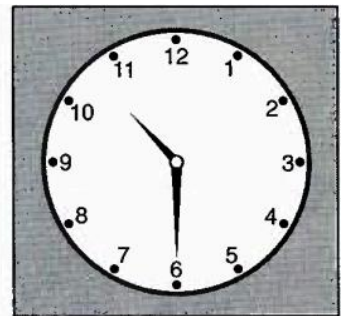

C

4 How much is the man's ticket?

- A £16.50
- B £15.00
- C £12.50

5 What was the weather like on John's holiday?

- A cloudy
- B rainy
- C snowy

6 Where are the man and the woman talking?

- A at the stadium
- B in the library
- C at the lecture

Task 2

Listen to the text. For statements (7-11) choose T if the statement is true, F if it is false according to the text. Write your answers on the separate answer sheet. You will listen to the text twice.

- | | T | F |
|---|--------------------------|--------------------------|
| 7 Linda wants to change a cassette because she dislikes it. | <input type="checkbox"/> | <input type="checkbox"/> |
| 8 Linda already knows what she wants to get. | <input type="checkbox"/> | <input type="checkbox"/> |
| 9 Frank recommends a famous band. | <input type="checkbox"/> | <input type="checkbox"/> |
| 10 Linda thinks the price of the cassette is reasonable. | <input type="checkbox"/> | <input type="checkbox"/> |
| 11 Linda has already seen the Irish band. | <input type="checkbox"/> | <input type="checkbox"/> |

Task 3

Listen to the text. For questions (12-16) choose the correct answer (A, B or C). Write your answers on the separate answer sheet. You will listen to the text twice.

- 12 How often does Sarah paint now?**
- A three days a week
 - B five days a week
 - C every evening
- 13 What did Sarah do when she was at primary school?**
- A She painted pictures of people.
 - B She learnt to use chalk.
 - C She drew scenes in pencil.
- 14 What pleased Sarah most about her painting holidays?**

- A meeting other artists
- B seeing beautiful scenery
- C receiving individual teaching

15 Which of these has Sarah done?

- A painted people in Greece
- B painted sunrises in Scotland
- C watched birds in Spain

16 What will the audience do after watching Sarah's video?

- A They'll fill in a questionnaire about the talk.
- B They'll look round an art exhibition.
- C They'll have a break and a drink

TEST 11

Task 1

Listen to the speakers. For questions (1 - 6) choose the correct answer (A, B or C). Write your answers on the separate answer sheet. You will listen to each recording twice.

1 When will Jane meet them?

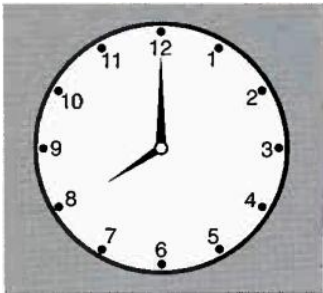

A

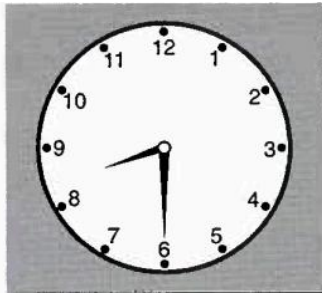

B

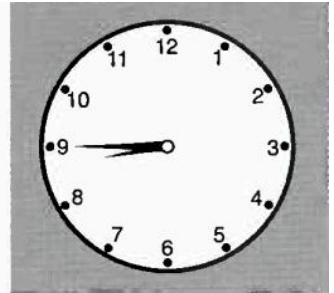

C

2 What is the man selling?

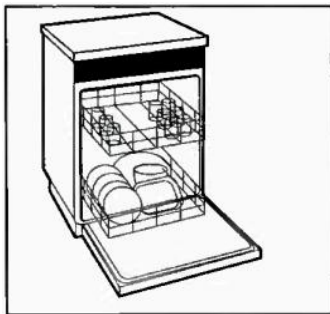

A

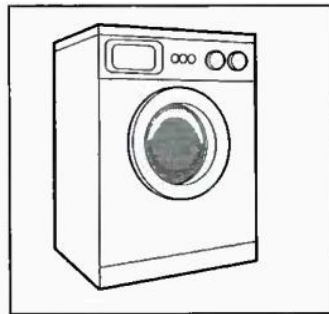

B

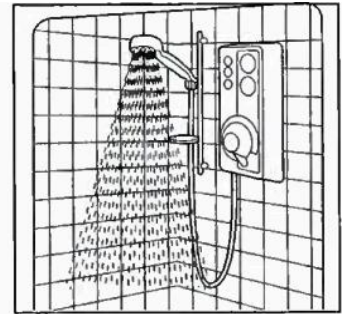

C

3 What is the weather forecast for tomorrow?

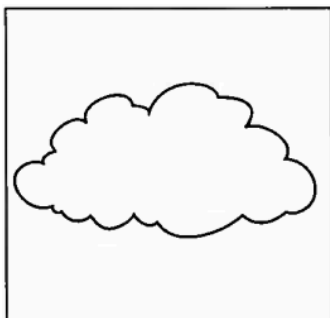

A

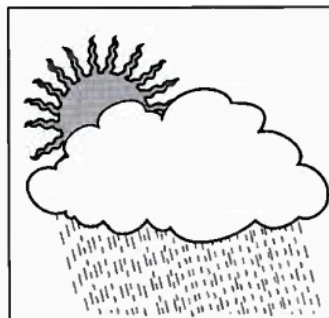

B

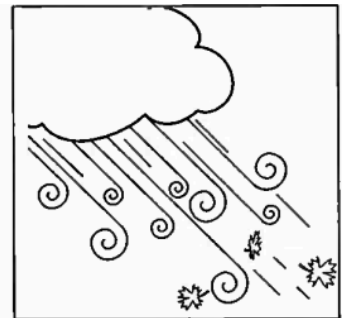

C

- 4 **What is the man going to buy?**
 A sunglasses
 B some medicine
 C a magazine
- 5 **Where does the pollution come from?**
 A the mountain
 B the village
 C the forest
- 6 **Which morning activity is for beginners?**
 A windsurfing
 B swimming
 C sailing

Task 2

Listen to the text. For statements (7-11) choose T if the statement is true, F if it is false according to the text. Write your answers on the separate answer sheet. You will listen to the text twice.

- | | T | F |
|---|--------------------------|--------------------------|
| 7 Lisa thinks you can enjoy a holiday without spending a lot. | <input type="checkbox"/> | <input type="checkbox"/> |
| 8 Ben has arranged to go on a seaside holiday. | <input type="checkbox"/> | <input type="checkbox"/> |
| 9 Lisa thinks a walking holiday is healthy. | <input type="checkbox"/> | <input type="checkbox"/> |
| 10 Ben thinks the weather in Scotland will be fine. | <input type="checkbox"/> | <input type="checkbox"/> |
| 11 Lisa prefers staying in hotels. | <input type="checkbox"/> | <input type="checkbox"/> |

Task 3

Listen to the text. For questions (12-16) choose the correct answer (A, B or C). Write your answers on the separate answer sheet. You will listen to the text twice.

- 12 **What do you need to do in order to really understand *My life*?**
 A to read it very slowly
 B to know about the writer's life
 C to read the writer's other books
- 13 **Why does John go to London in *Goodbye to the fields*?**
 A Because his parents do not like the country.
 B Because his father has to be close to his work.
 C Because his parents both come from the city.

- 14 Why does the presenter like *Cooking for one*?**
A Because it taught her to cook Italian food.
B Because it contains only easy meals.
C Because she now likes cooking.
- 15 What is wrong with *Holidays in Europe*?**
A It leaves out well-known places.
B The maps are not very good.
C It is too expensive.
- 16 Who will the next week's programme be useful for?**
A those who enjoy reading reports
B those who are trying to save money
C those who are planning to buy presents

TEST 12

Task 1

Listen to the speakers. For questions (1 - 6) choose the correct answer (A, B or C). Write your answers on the separate answer sheet. You will listen to each recording twice.

1 What can festival visitors see every day?

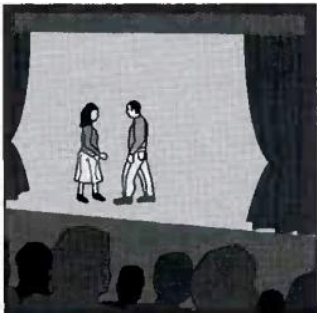

A

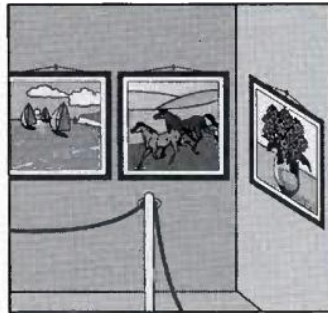

B

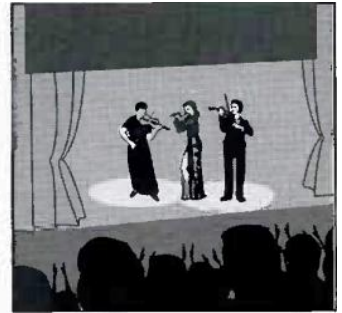

C

2 What time is the woman's hair appointment?

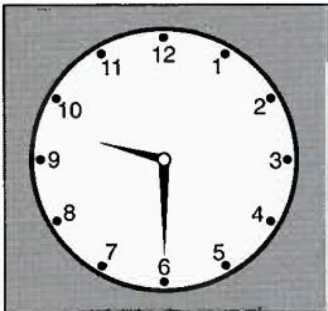

A

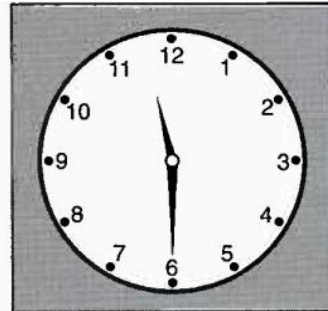

B

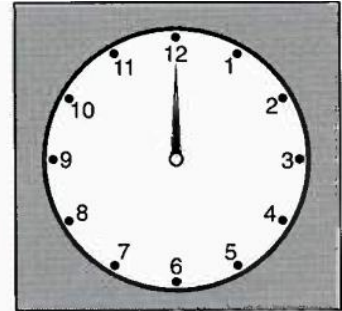

C

3 Which sport has the man just started?

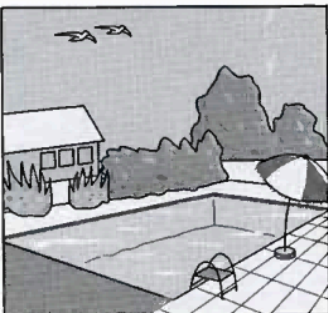

A

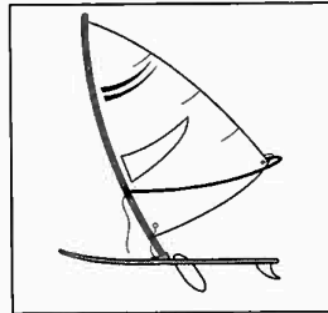

B

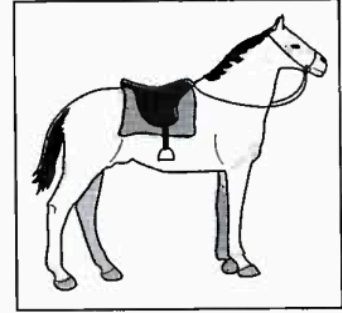

C

- 4 Where will the woman go first after work?**
A to play tennis
B shopping
C to the restaurant
- 5 What souvenir will the boy's mother bring?**
A a T-shirt
B a sports model car
C a taxi model car
- 6 What does the man decide to take Tracy?**
A some magazines
B some cassettes
C some sweets

Task 2

Listen to the text. For statements (7-11) choose T if the statement is true, F if it is false according to the text. Write your answers on the separate answer sheet. You will listen to the text twice.

- | | T | F |
|---|--------------------------|--------------------------|
| 7 Anna begins by asking her father to collect her from the party. | <input type="checkbox"/> | <input type="checkbox"/> |
| 8 Some of Tom's relations will be at the party. | <input type="checkbox"/> | <input type="checkbox"/> |
| 9 Anna's father is worried about her attending the party. | <input type="checkbox"/> | <input type="checkbox"/> |
| 10 Anna's father will take them to the party before the film starts. | <input type="checkbox"/> | <input type="checkbox"/> |
| 11 Anna's father insists that she leaves the party at 12.00. | <input type="checkbox"/> | <input type="checkbox"/> |

Task 3

Listen to the text. For questions (12-16) choose the correct answer (A, B or C). Write your answers on the separate answer sheet. You will listen to the text twice.

- 12 What did John do for his most recent television programme?**
A He drove from the North to the South Pole.
B He filmed relaxing beach holidays.
C He went to the Pacific Ocean for a year.
- 13 Why is John giving up very long trips?**
A Because he's too old now.
B Because he's been everywhere.
C Because they're too tiring.

- 14 What does John want to encourage other people to do?**
A to be brave about travelling to new places
B to lose their fear of flying
C to make more trips alone
- 15 Why does John want to spend more time near home?**
A His family might need him.
B His wife misses him.
C He has very young children.
- 16 What has John already written?**
A some newspaper articles
B some travel books
C some poems

TEST 13

Task 1

Listen to the speakers. For questions (1 - 6) choose the correct answer (A, B or C). Write your answers on the separate answer sheet. You will listen to each recording twice.

1 What was damaged in the storm?

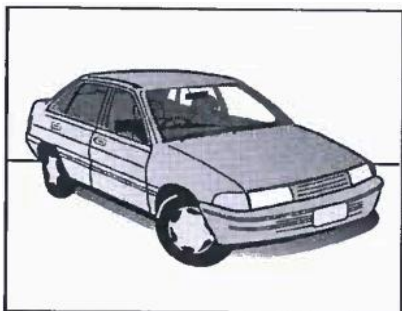

A

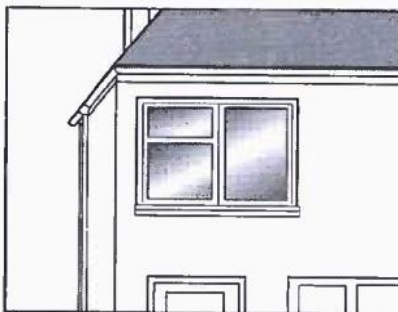

B

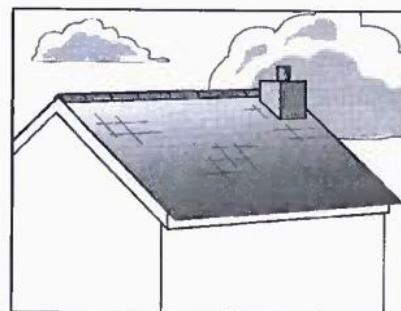

C

2 Which is the woman's jacket?

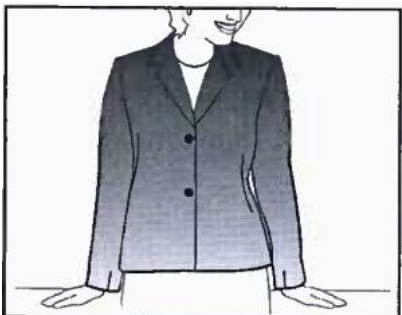

A

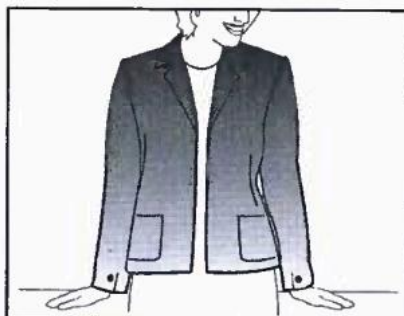

B



C

3 Which sport is NOT included in the price of the holiday?

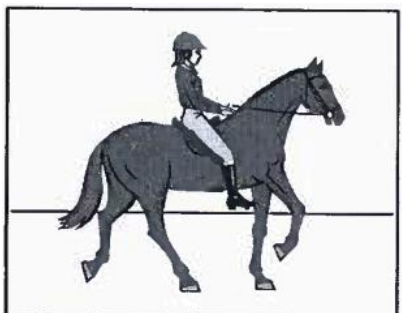

A



B

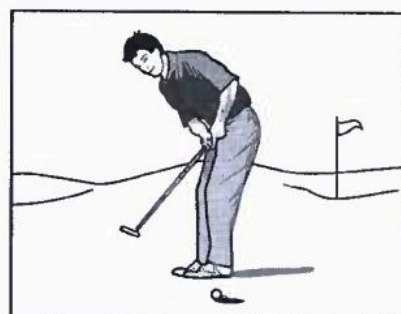

C

- 4 Which postcard will they send?**
A the one with a beach and a town
B the one with a castle
C the one with a cottage
- 5 Where do they decide to go?**
A a photograph exhibition
B a sculpture exhibition
C a clothes exhibition
- 6 What will the boy do first?**
A go to the library
B play tennis
C help his friend repair his bike

Task 2

Listen to the text. For statements (7-11) choose T if the statement is true, F if it is false according to the text. Write your answers on the separate answer sheet. You will listen to the text twice.

- | | T | F |
|--|--------------------------|--------------------------|
| 7 Susanna feels shy about playing her violin in public. | <input type="checkbox"/> | <input type="checkbox"/> |
| 8 Carl and Susanna share the same opinion about practising their instruments regularly. | <input type="checkbox"/> | <input type="checkbox"/> |
| 9 Susanna's parents refuse to allow her to give up violin lessons. | <input type="checkbox"/> | <input type="checkbox"/> |
| 10 Carl's aim is to have a career in music. | <input type="checkbox"/> | <input type="checkbox"/> |
| 11 Carl persuades Susanna to take part in the concert. | <input type="checkbox"/> | <input type="checkbox"/> |

Task 3

Listen to the text. For questions (12-16) choose the correct answer (A, B or C). Write your answers on the separate answer sheet. You will listen to the text twice.

- 12 How long has Britta lived in Berlin?**
A four years
B six years
C twenty years
- 13 What does Britta say about living in Berlin?**
A She can't sleep at night because of the traffic noise.
B She misses the museums and theatres in Bonn.
C She likes living in a big, busy city.

- 14 What is the area of Berlin where Britta lives like?**
- A** It's a rather expensive place to live.
 - B** It's a good place to eat out.
 - C** It's a long way from the city centre.
- 15 How does Britta usually travel around in Berlin?**
- A** She walks.
 - B** She uses her bicycle.
 - C** She uses the tram or bus.
- 16 According to Britta, where does her nephew Philippe like going to?**
- A** to the park with her
 - B** to the shops with his parents
 - C** to a gallery with her

TEST 14

Task 1

Listen to the speakers. For questions (1 - 6) choose the correct answer (A, B or C). Write your answers on the separate answer sheet. You will listen to each recording twice.

1 Which animals did the children see?

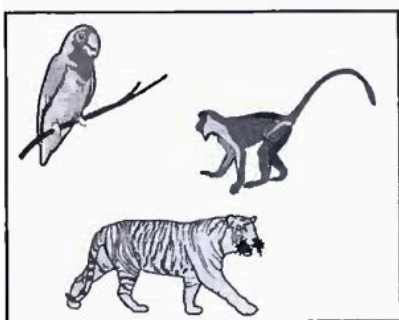

A

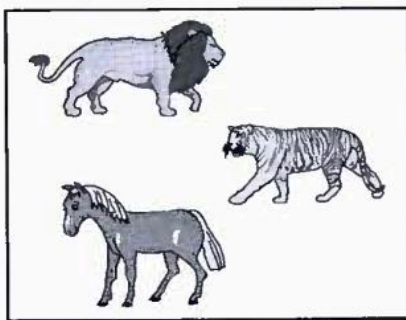

B

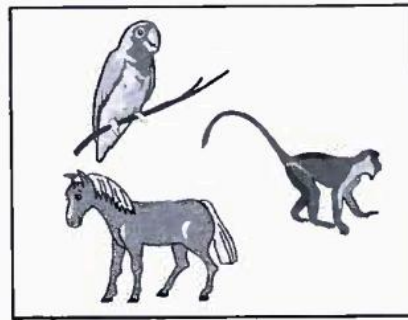

C

2 Which TV programme is on first?



A



B

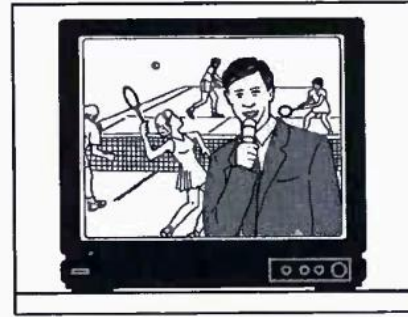

C

3 What has the woman lost?



A

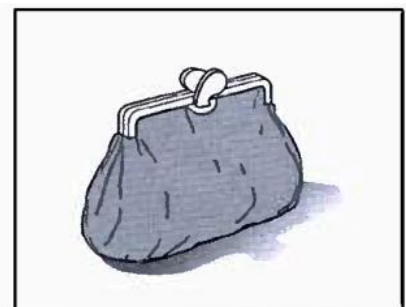

B



C

4 Which sport will the woman learn on holiday?

- A swimming
- B water skiing
- C windsurfing

5 What does the boy decide to buy for his grandmother?

- A a wooden jewelry box
- B some perfume
- C a pair of earrings

6 What time is the man's appointment?

- A at 6.15
- B at 6.35
- C at 6.50

Task 2

Listen to the text. For statements (7-11) choose T if the statement is true, F if it is false according to the text. Write your answers on the separate answer sheet. You will listen to the text twice.

- | | T | F |
|--|--------------------------|--------------------------|
| 7 Alex and Rose's mother have gone to their Grandad's. | <input type="checkbox"/> | <input type="checkbox"/> |
| 8 Alex tries to persuade Rose to cook supper. | <input type="checkbox"/> | <input type="checkbox"/> |
| 9 Alex likes some of the music at <i>Classic Express</i> . | <input type="checkbox"/> | <input type="checkbox"/> |
| 10 Alex has eaten at <i>Classic Express</i> before. | <input type="checkbox"/> | <input type="checkbox"/> |
| 11 Alex and Rose are going to walk to the restaurant together. | <input type="checkbox"/> | <input type="checkbox"/> |

Task 3

Listen to the text. For questions (12-16) choose the correct answer (A, B or C). Write your answers on the separate answer sheet. You will listen to the text twice.

- 12 Why does Frank find ships quickly?
- A Because he reads history books.
 - B Because he is a professional diver.
 - C Because he uses the latest equipment.
- 13 What does Frank say about the ship called *The Seabird*?
- A It was built in 1859.
 - B It sank in a storm.
 - C It was badly made.
- 14 What is known about Frank's wedding ring?

- A It was made from gold he found himself.
- B It is worth £88,000.
- C It was found by a friend.

15 What does Frank's wife wants him to do?

- A to stop diving
- B to give things to museums
- C to sell some of his collection

16 How did Frank learn to dive?

- A by joining a diving club
- B by going on a diving holiday
- C by teaching himself

TEST 15

Task 1

Listen to the speakers. For questions (1 - 6) choose the correct answer (A, B or C). Write your answers on the separate answer sheet. You will listen to each recording twice.

1 What is the weather forecast for tomorrow?



A

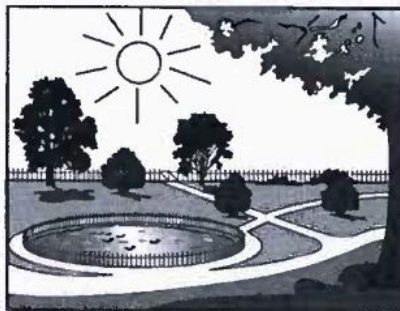

B



C

2 Which exercise is the teacher describing?

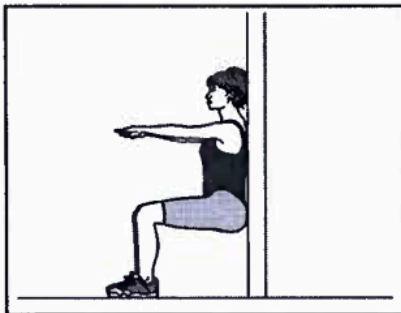

A

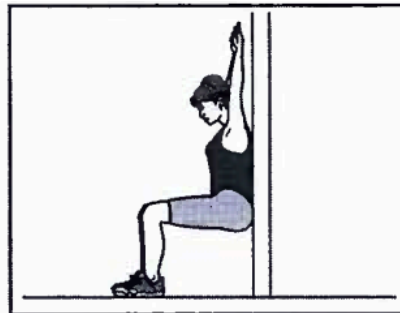

B

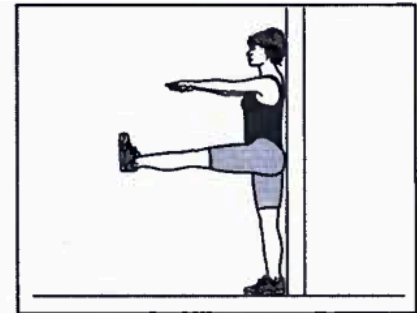

C

3 What time will the train to London leave?



A

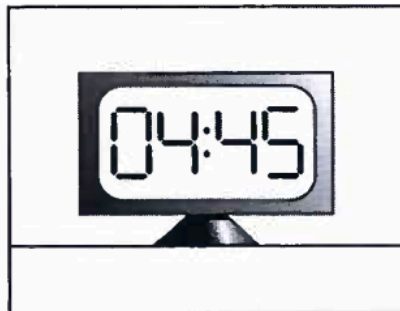

B



C

- 4 What will they buy at the supermarket?**
A some biscuits
B a cake
C some ice cream
- 5 What will the girl take with her on holiday?**
A a suitcase
B a back pack
C a big sports bag
- 6 Which sport will the boy do soon at the centre?**
A windsurfing
B diving
C sailing

Task 2

Listen to the text. For statements (7-11) choose T if the statement is true, F if it is false according to the text. Write your answers on the separate answer sheet. You will listen to the text twice.

- | | T | F |
|---|--------------------------|--------------------------|
| 7 Peter's mother is planning to go to Scotland. | <input type="checkbox"/> | <input type="checkbox"/> |
| 8 Peter's father hopes to have an active holiday. | <input type="checkbox"/> | <input type="checkbox"/> |
| 9 Peter's father will pay for everything at the campsite. | <input type="checkbox"/> | <input type="checkbox"/> |
| 10 Peter has met Jim's son more than once. | <input type="checkbox"/> | <input type="checkbox"/> |
| 11 Peter suggests everyone could meet before the trip to Scotland. | <input type="checkbox"/> | <input type="checkbox"/> |

Task 3

Listen to the text. For questions (12-16) choose the correct answer (A, B or C). Write your answers on the separate answer sheet. You will listen to the text twice.

- 12 What did Rachel do before her children were born?**
A She worked as an art teacher.
B She worked as a painter.
C She worked as an actor.
- 13 Who first thought of doing a show at a party?**
A Rachel's husband
B Rachel's children
C Rachel's parents

- 14 In what way does Rachel's neighbour Lena help her?**
- A** by making some dolls for the shows
 - B** by performing in the shows
 - C** by writing the music for the shows
- 15 What happened when Rachel did a play about a lion?**
- A** The children laughed too much.
 - B** The children were frightened.
 - C** The children's parents complained.
- 16 How do Rachel's daughters help her?**
- A** They show new dolls to their school friends.
 - B** They think of ideas for new stories.
 - C** They give her their opinions on her new plays.

TEST 16

Task 1

Listen to the speakers. For questions (1 - 6) choose the correct answer (A, B or C). Write your answers on the separate answer sheet. You will listen to each recording twice.

1 Which ring has the woman lost?



A



B



C

2 Which is Gary's room?

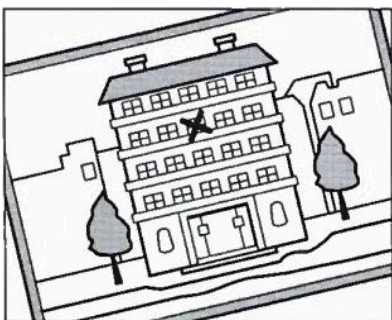

A

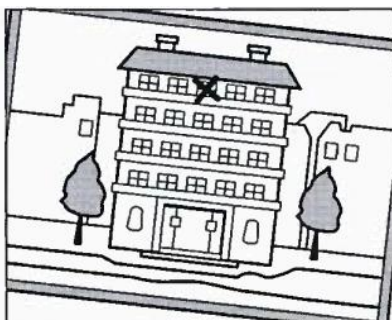

B

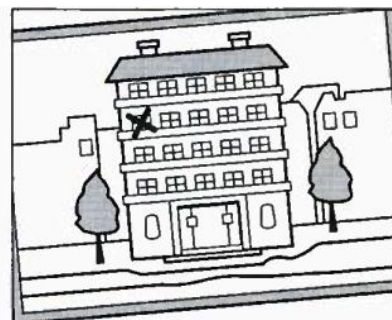

C

3 What will be on television at 10 o'clock this evening?



A

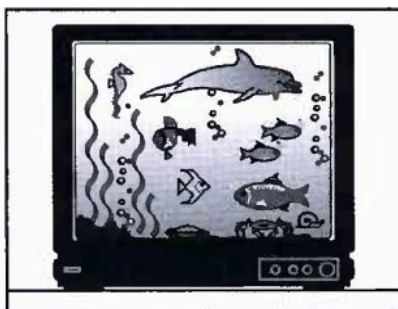

B



C

- 4 Which of Miranda's things will Lucy be able to use?**
A a tennis racket
B tennis balls
C tennis shoes
- 5 Where will the party be?**
A at the nightclub
B at the concert
C at Maria's place
- 6 What did the man buy?**
A some orange juice and grapes
B some grapes and strawberries
C some orange juice and strawberries

Task 2

Listen to the text. For statements (7-11) choose T if the statement is true, F if it is false according to the text. Write your answers on the separate answer sheet. You will listen to the text twice.

- | | T | F |
|---|--------------------------|--------------------------|
| 7 Ella is happy to be alone during the holidays. | <input type="checkbox"/> | <input type="checkbox"/> |
| 8 Ella has a lot in common with her friends. | <input type="checkbox"/> | <input type="checkbox"/> |
| 9 The family's last camping trip was unsuccessful. | <input type="checkbox"/> | <input type="checkbox"/> |
| 10 Someone has asked Ella to look after a horse in the holidays. | <input type="checkbox"/> | <input type="checkbox"/> |
| 11 Ella's father is keen for her to spend the holidays relaxing. | <input type="checkbox"/> | <input type="checkbox"/> |

Task 3

Listen to the text. For questions (12-16) choose the correct answer (A, B or C). Write your answers on the separate answer sheet. You will listen to the text twice.

- 12 Why did Paul choose the part of Africa he visited?**
A It is good for walking.
B It will soon change.
C He had been there before.
- 13 What made the team's journey slow?**
A clearing paths through the forest
B finding somewhere safe to camp
C carrying heavy equipment

- 14 What did Paul worry about during the trip?**
- A the number of dangerous animals
 - B getting the information he needed
 - C being responsible for a team of people
- 15 Why were the team grateful to a fisherman they met?**
- A He let everyone rest on his boat.
 - B He helped one of them who was ill.
 - C He told them which direction to take.
- 16 How does Paul feel now he is back home?**
- A He is planning to do another trip.
 - B He misses the people in the team
 - C He thinks the trip was a valuable experience.

TEST 17

Task 1

Listen to the speakers. For questions (1 - 6) choose the correct answer (A, B or C). Write your answers on the separate answer sheet. You will listen to each recording twice.

1 Which TV programme is on at 9 o'clock tonight?



A

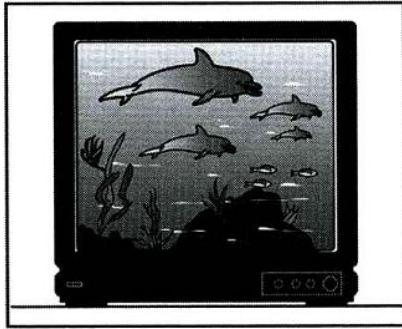

B

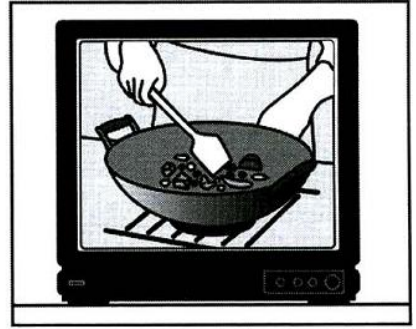

C

2 What has the girl forgotten to bring?



A

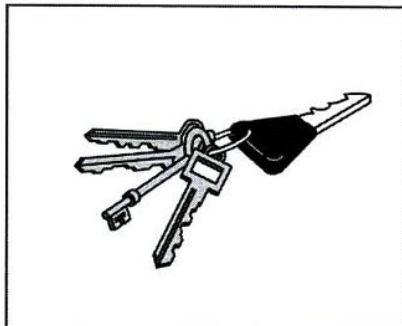

B

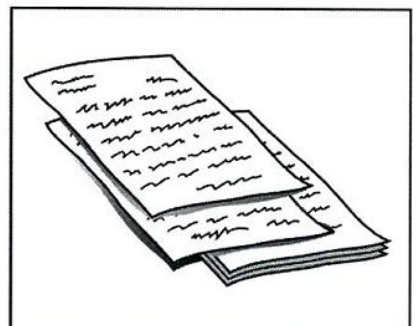

C

3 What does the man want the woman to help him?

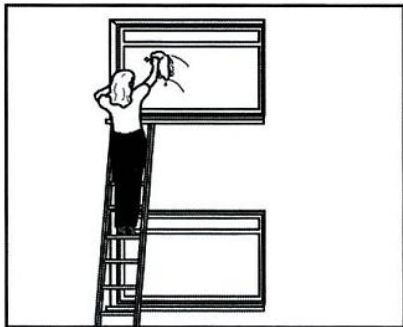

A

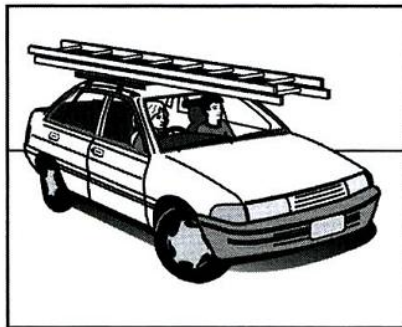

B

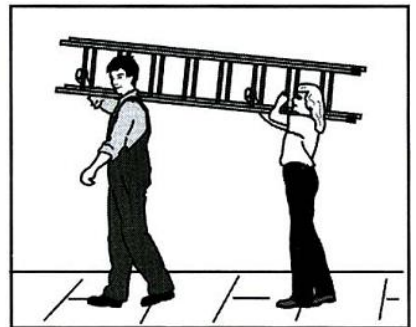

C

- 4 Where will the friends meet?**
A outside the cinema
B at the coffee bar
C at the bus stop
- 5 How will the man book tickets for the show?**
A on the Internet
B by posting a form from a magazine
C by phone
- 6 What will the man do this winter?**
A work as a gardener
B get a job in a supermarket
C get a building job abroad

Task 2

Listen to the text. For statements (7-11) choose T if the statement is true, F if it is false according to the text. Write your answers on the separate answer sheet. You will listen to the text twice.

- | | T | F |
|---|--------------------------|--------------------------|
| 7 Catherine finds it hard to understand why Marcus has so much homework. | <input type="checkbox"/> | <input type="checkbox"/> |
| 8 Marcus agrees that he could change his weekend activities. | <input type="checkbox"/> | <input type="checkbox"/> |
| 9 Catherine thinks visiting the museum was a good experience for Marcus. | <input type="checkbox"/> | <input type="checkbox"/> |
| 10 Catherine offers to show Marcus the maths homework she has already done. | <input type="checkbox"/> | <input type="checkbox"/> |
| 11 After talking to Catherine, Marcus feels more confident about his homework. | <input type="checkbox"/> | <input type="checkbox"/> |

Task 3

Listen to the text. For questions (12-16) choose the correct answer (A, B or C). Write your answers on the separate answer sheet. You will listen to the text twice.

- 12 Where is Angela working at the moment?**
A Britain
B the USA
C Asia

- 13 What did Angela bring home from Hong Kong?**
A pictures
B carpets
C furniture
- 14 What time does Angela's working day begin?**
A at 8.30 am
B at 6.30 pm
C at 10.00 am
- 15 Where did Angela meet her boyfriend?**
A at her sister's house
B at university
C in Hong Kong
- 16 What does Angela do to relax?**
A She cooks a meal.
B She goes sailing.
C She goes shopping.

TEST 18

Task 1

Listen to the speakers. For questions (1 - 6) choose the correct answer (A, B or C). Write your answers on the separate answer sheet. You will listen to each recording twice.

1 Where are the dictionaries?

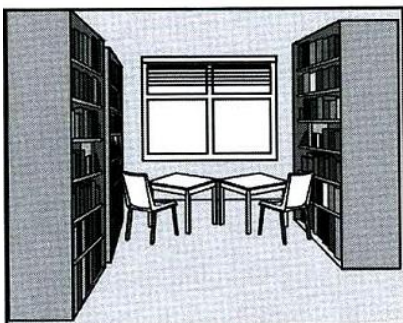

A

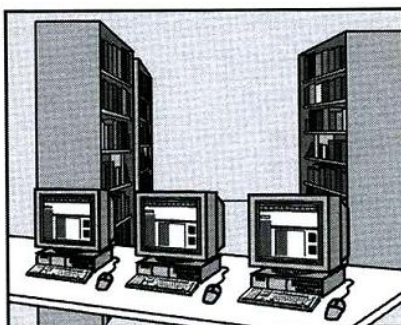

B

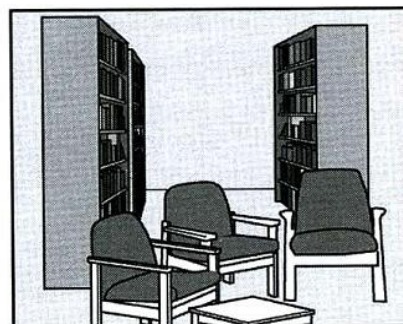

C

2 What is the man's job now?



A

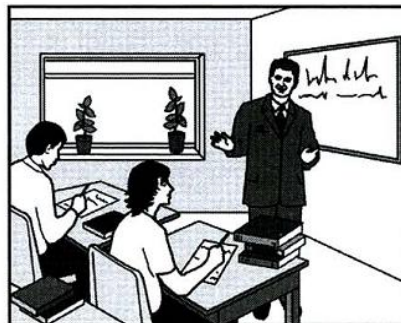

B



C

3 What did the woman leave in the restaurant?



A

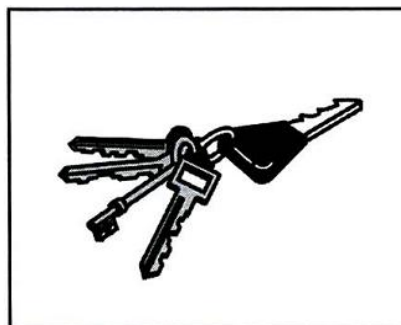

B

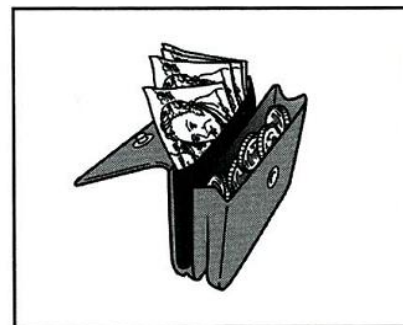

C

- 4 Which evening dress does the woman decide to wear?**
A a long-sleeved black dress
B a short-sleeved long dress
C a short-sleeved black dress
- 5 Which calendar will the boy buy?**
A the one with mountains
B the one with boats
C the one with animals
- 6 Where is the bicycle?**
A near a street light
B near a tree
C in the parking place

Task 2

Listen to the text. For statements (7-11) choose T if the statement is true, F if it is false according to the text. Write your answers on the separate answer sheet. You will listen to the text twice.

- | | T | F |
|---|--------------------------|--------------------------|
| 7 Sarah was expecting to enjoy the film. | <input type="checkbox"/> | <input type="checkbox"/> |
| 8 Marco and Sarah agree that the city in the film was London. | <input type="checkbox"/> | <input type="checkbox"/> |
| 9 Marco feels that the length of the film made it rather boring. | <input type="checkbox"/> | <input type="checkbox"/> |
| 10 Sarah was upset about how some of the audience behaved during the film. | <input type="checkbox"/> | <input type="checkbox"/> |
| 11 Marco thinks this film is the best the director has made. | <input type="checkbox"/> | <input type="checkbox"/> |

Task 3

Listen to the text. For questions (12-16) choose the correct answer (A, B or C). Write your answers on the separate answer sheet. You will listen to the text twice.

- 12 What does Jack like most about living in Swanton?**
A opportunities for climbing nearby
B a variety of activities in the town
C interesting wildlife near the town
- 13 Which of the following is NOT available in Swanton?**
A a music festival
B a football club
C an arts centre

- 14 Which of the following is TRUE about the consequences of pollution in Swanton?**
- A** the mass death of fish in the river
 - B** the reduction in the number of wild birds
 - C** the destruction of plant life
- 15 What does Jack say about the way Swanton has changed?**
- A** He preferred the town when it was smaller.
 - B** He thinks it is a more interesting place.
 - C** He is sorry that there are fewer jobs available.
- 16 Why is Jack positive about the future of Swanton?**
- A** The number of visitors has increased.
 - B** The infrastructure has improved.
 - C** Advanced technologies have been introduced.

TEST 19

Task 1

Listen to the speakers. For questions (1 - 6) choose the correct answer (A, B or C). Write your answers on the separate answer sheet. You will listen to each recording twice.

1 What should Suzie take to Emma's house?

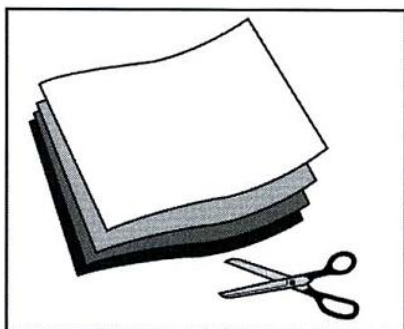

A



B

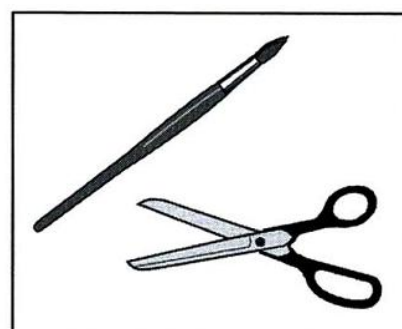

C

2 What kind of T-shirt did the boy choose?



A



B

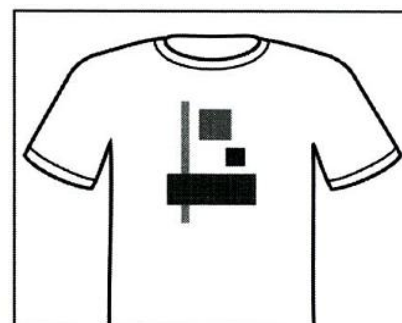

C

3 What frightened the man?

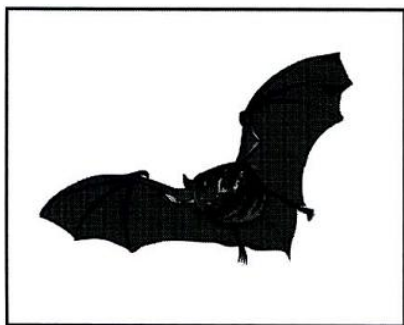

A

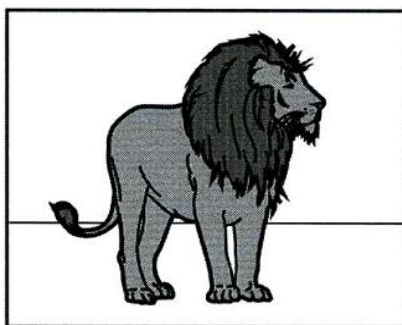

B

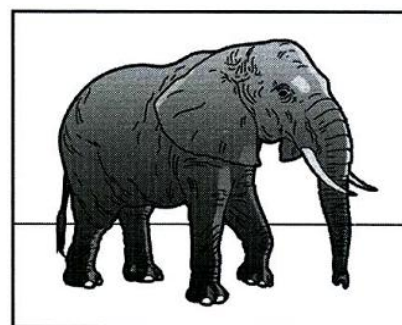

C

- 4 **What regular exercise does David do at the moment?**
 A works out
 B goes swimming
 C plays tennis
- 5 **Where is the man calling from?**
 A a client's house
 B a bar down the road
 C a farmhouse near the bridge
- 6 **Where is the girl's purse?**
 A on the table
 B in the bag
 C under the sofa

Task 2

Listen to the text. For statements (7-11) choose T if the statement is true, F if it is false according to the text. Write your answers on the separate answer sheet. You will listen to the text twice.

- | | T | F |
|---|--------------------------|--------------------------|
| 7 Maria would like to travel a lot as part of her job. | <input type="checkbox"/> | <input type="checkbox"/> |
| 8 Maria is confident she will be able to work for an airline. | <input type="checkbox"/> | <input type="checkbox"/> |
| 9 Maria and Rolf agree it is important to have a good salary. | <input type="checkbox"/> | <input type="checkbox"/> |
| 10 Maria hopes to work for several different employers. | <input type="checkbox"/> | <input type="checkbox"/> |
| 11 Rolf's ambition is to manage his own company one day. | <input type="checkbox"/> | <input type="checkbox"/> |

Task 3

Listen to the text. For questions (12-16) choose the correct answer (A, B or C). Write your answers on the separate answer sheet. You will listen to the text twice.

- 12 **What is TRUE about Elena's studies at ballet school in New York?**
 A She found it quite easy.
 B She learned to communicate with other students.
 C She learned to be independent.
- 13 **What does Elena say about the ballet called *Cinderella*?**
 A Children will enjoy it.
 B The music was unfamiliar to her.
 C She saw it when she was a child.

14 What does Elena like doing in her free time?

A going sightseeing

B going clubbing

C going shopping

15 What DOESN'T Elena do for her fans?

A gives them a flower

B signs their programmes

C sends them a free ticket

16 What does Elena like best about her job?

A appearing on television

B doing something she loves

C travelling to different countries

TEST 20

Task 1

Listen to the speakers. For questions (1-6) choose the correct answer (A, B or C). Write your answers on the separate answer sheet. You will listen to each recording twice.

1 What present will they take?



A

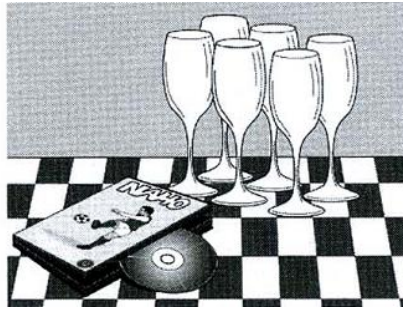

B

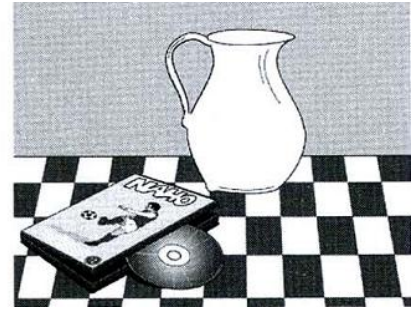

C

2 What is the grandmother's job now?

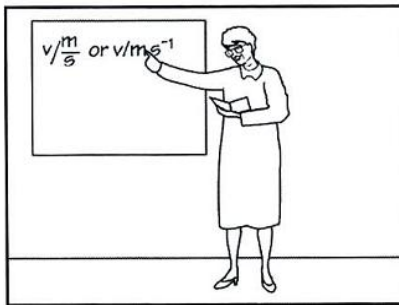

A



B



C

3 What will the man do first?



A

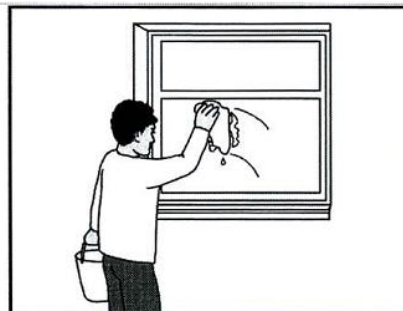

B



C

- 4 What did the thieves steal?**
A a CD player
B a TV set
C a chest of drawers
- 5 What will the woman eat tonight?**
A a burger and chips
B some sandwiches
C a pizza
- 6 Which button has the boy lost?**
A a pocket button
B a collar button
C a sleeve button

Task 2 PET 6 test 3 listening 4

Listen to the text. For statements (7-11) choose T if the statement is true, F if it is false according to the text. Write your answers on the separate answer sheet. You will listen to the text twice.

- | | T | F |
|--|--------------------------|--------------------------|
| 7 Julia's father thinks that studying business may be boring. | <input type="checkbox"/> | <input type="checkbox"/> |
| 8 Julia's father believes Julia's friend is making the wrong choice. | <input type="checkbox"/> | <input type="checkbox"/> |
| 9 Julia's father thinks she might find studying business too difficult. | <input type="checkbox"/> | <input type="checkbox"/> |
| 10 Julia is confident about her maths. | <input type="checkbox"/> | <input type="checkbox"/> |
| 11 Julia is keen to consider her father's suggestion. | <input type="checkbox"/> | <input type="checkbox"/> |

Task 3

Listen to the text. For questions (12-16) choose the correct answer (A, B or C). Write your answers on the separate answer sheet. You will listen to the text twice.

- 12 Which of the following is NOT Sarah's responsibility?**
A to supervise eleven employees
B to travel all round the world
C to present weather forecasts
- 13 When Sarah does a weather forecast,**
A she prepares it in advance.
B she sometimes forgets her words.
C she worries about making a mistake.

- 14 What is TRUE about Sarah's husband?**
- A He works on the same days each week.
 - B He doesn't have time to do anything about the house.
 - C He spends a lot of time travelling.
- 15 Why is Sarah pleased?**
- A She has got her pilot's licence.
 - B She taught her husband to play tennis.
 - C She took part in a long race.
- 16 What makes Sarah popular?**
- A She travels to distant places.
 - B Her programme is broadcast worldwide.
 - C She takes a lot of photos with different people.

TEST 21

Task 1

Listen to the speakers. For questions (1 - 6) choose the correct answer (A, B or C). Write your answers on the separate answer sheet. You will listen to each recording twice.

1 Which photograph does the man like?

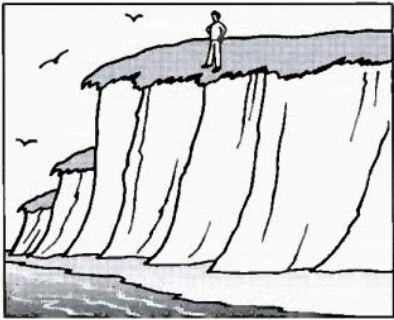

A

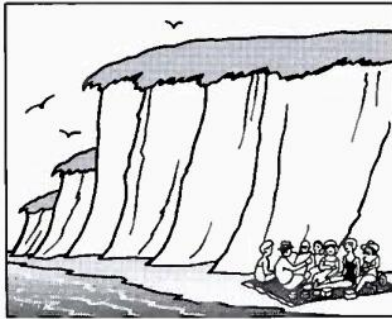

B

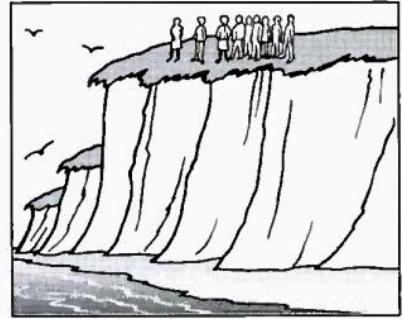

C

2 Which is the best vehicle for the man?

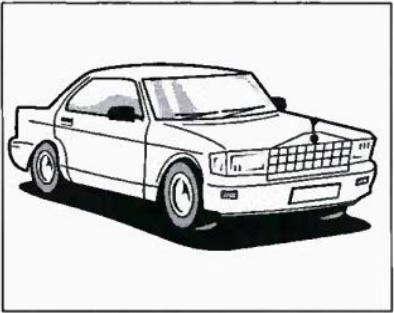

A

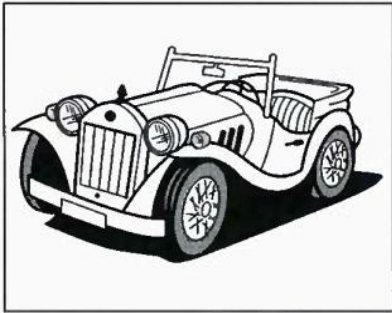

B

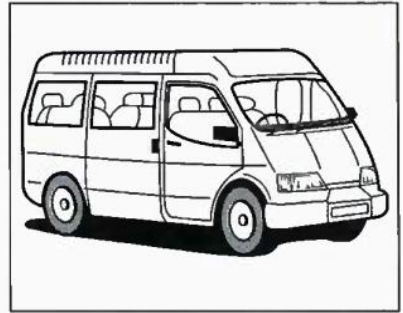

C

3 What would John like to be?

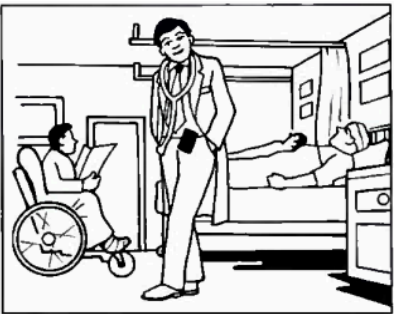

A

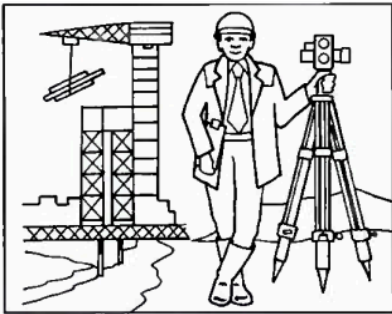

B

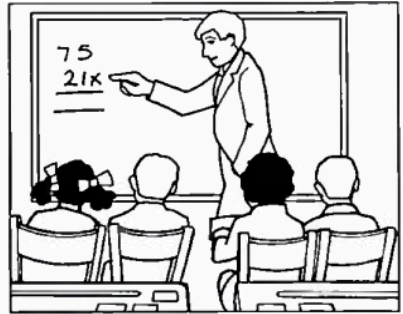

C

- 4 When is the girl having a party?**
A on Thursday, 13
B on Friday, 14
C on Saturday, 15
- 5 What will the woman repair next?**
A a tyre
B a football
C a window
- 6 What will the weather be like tomorrow afternoon?**
A rainy and windy
B rainy and chilly
C sunny and windy

Task 2

Listen to the text. For statements (7-11) choose T if the statement is true, F if it is false according to the text. Write your answers on the separate answer sheet. You will listen to the text twice.

- | | T | F |
|---|--------------------------|--------------------------|
| 7 Sophie's mother works in the town where they live. | <input type="checkbox"/> | <input type="checkbox"/> |
| 8 Sophie enjoys shopping in Birmingham. | <input type="checkbox"/> | <input type="checkbox"/> |
| 9 William feels confident about finding his way around Birmingham. | <input type="checkbox"/> | <input type="checkbox"/> |
| 10 William persuades Sophie to buy a different CD from him. | <input type="checkbox"/> | <input type="checkbox"/> |
| 11 Sophie is disappointed to have her birthday present early. | <input type="checkbox"/> | <input type="checkbox"/> |

Task 3

Listen to the text. For questions (12-16) choose the correct answer (A, B or C). Write your answers on the separate answer sheet. You will listen to the text twice.

- 12 What did Vanessa worry about before the trip?**
A They wouldn't be prepared.
B The conditions would be bad.
C The baby would get ill.
- 13 How did Vanessa feel when they reached Singapore?**
A She wondered if she should fly home.
B She was worried about the boat.
C She enjoyed the break from travelling.

- 14 Why was Vanessa's father-in-law particularly helpful?**
- A** He was a good cook.
 - B** He looked after the baby.
 - C** He helped to sail the boat.
- 15 How did the boat journey affect the baby?**
- A** He learnt to walk late.
 - B** He doesn't play by himself.
 - C** He only likes certain food.
- 16 What DOESN'T Vanessa advise people sailing with children?**
- A** to take more than one child
 - B** to go for a short time
 - C** not to let children get bored.

TEST 22

Task 1

Listen to the speakers. For questions (1 - 6) choose the correct answer (A, B or C). Write your answers on the separate answer sheet. You will listen to each recording twice.

1 What time will Robin leave the house?

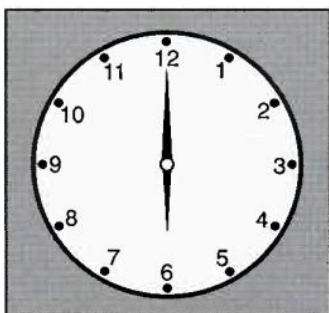

A

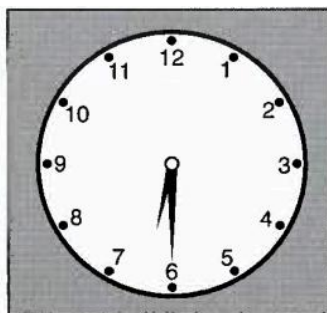

B

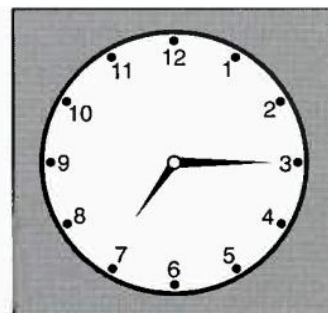

C

2 What did the woman buy?

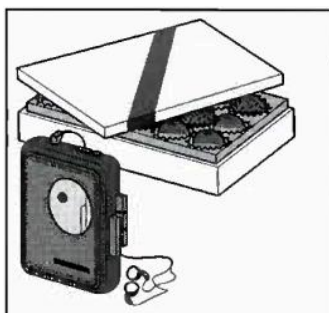

A

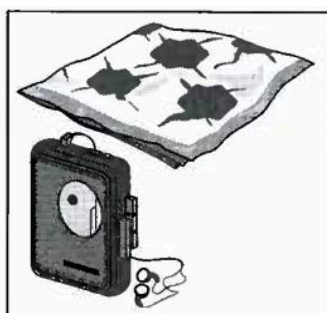

B

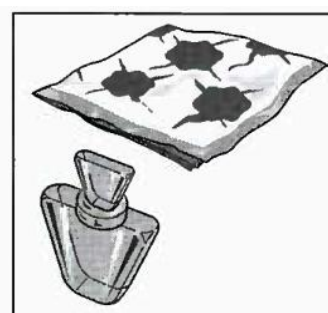

C

3 Where's the TV guide?



A

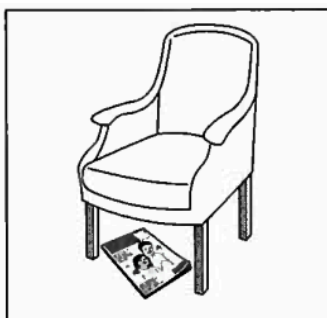

B

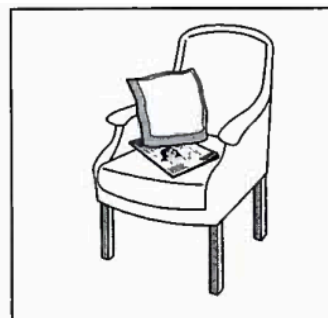

C

4 Where will the tourists go last?

- A to a café in the town park
- B on excursion to the gardens
- C on a boat trip

5 Which prize has the man just won?

- A a glass bowl
- B a cup
- C a silver plate

6 What was the man's first job?

- A a postman
- B a window cleaner
- C a builder

Task 2

Listen to the text. For statements (7-11) choose T if the statement is true, F if it is false according to the text. Write your answers on the separate answer sheet. You will listen to the text twice.

- | | T | F |
|---|--------------------------|--------------------------|
| 7 Marcus is never in time for work. | <input type="checkbox"/> | <input type="checkbox"/> |
| 8 Marcus agrees that cycling to work would be good for him. | <input type="checkbox"/> | <input type="checkbox"/> |
| 9 Marcus believes employers should provide buses. | <input type="checkbox"/> | <input type="checkbox"/> |
| 10 Marcus agrees to try coming to work by bus tomorrow. | <input type="checkbox"/> | <input type="checkbox"/> |
| 11 Cora suggests that Marcus is lazy. | <input type="checkbox"/> | <input type="checkbox"/> |

Task 3

Listen to the text. For questions (12-16) choose the correct answer (A, B or C). Write your answers on the separate answer sheet. You will listen to the text twice.

12 When did Toby get a job with Atkins Engineering?

- A when he was a university student
- B as soon as he finished university
- C six months after he finished university

13 What is Toby working on at the moment?

- A a new motorway
- B houses and flats
- C a new airport

14 What DIDN'T Toby expect when he began working?

- A to have mostly an office job
- B to spend a lot of time talking with other people
- C to do a lot of designing

15 What is TRUE about young people's expectations concerning the job?

- A monotonous duties
- B bad chances for promotion
- C a low salary

16 What is a disadvantage of the job for Toby?

- A a long working day
- B difficulties with organizing his spare time
- C a six weeks' holiday

TEST 23

Task 1

Listen to the speakers. For questions (1 - 6) choose the correct answer (A, B or C). Write your answers on the separate answer sheet. You will listen to each recording twice.

1 Which house did the woman stay in?

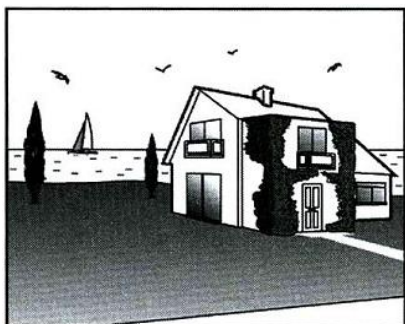

A

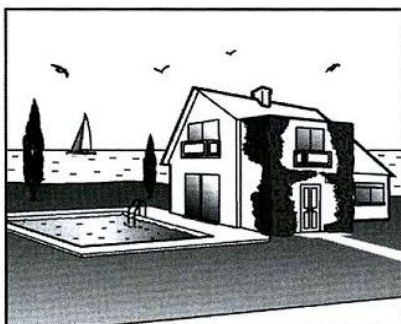

B

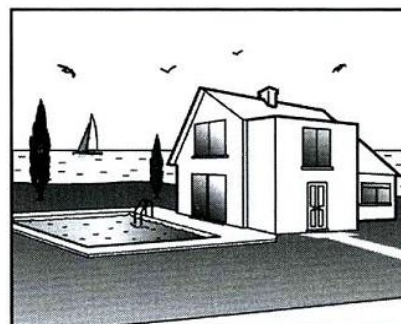

C

2 What does the girl's pen friend look like now?



A



B



C

3 Which painting does the woman decide to buy?



A

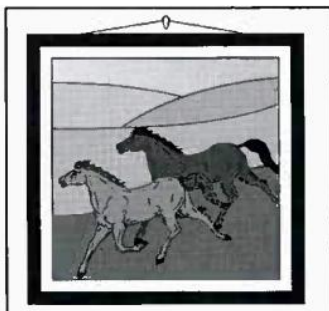

B



C

- 4 Which sport will they do tomorrow?**
 A diving
 B horse-riding
 C cycling
- 5 What can you see on the television programme?**
 A Earth as seen from space
 B satellite technology
 C African wildlife
- 6 Where will they have something to eat?**
 A at the airport
 B at a café
 C at a petrol station

Task 2

Listen to the text. For statements (7-11) choose T if the statement is true, F if it is false according to the text. Write your answers on the separate answer sheet. You will listen to the text twice.

- | | T | F |
|---|--------------------------|--------------------------|
| 7 Rob could hear music from Kim's flat. | <input type="checkbox"/> | <input type="checkbox"/> |
| 8 Rob feels hurt because Kim didn't ask him round. | <input type="checkbox"/> | <input type="checkbox"/> |
| 9 Rob plays music when he has visitors. | <input type="checkbox"/> | <input type="checkbox"/> |
| 10 Kim dislikes working in silence. | <input type="checkbox"/> | <input type="checkbox"/> |
| 11 Kim prefers to work during the day. | <input type="checkbox"/> | <input type="checkbox"/> |

Task 3

Listen to the text. For questions (12-16) choose the correct answer (A, B or C). Write your answers on the separate answer sheet. You will listen to the text twice.

- 12 Which of the following is NOT required to enter the competition?**
 A to between 6 and 65 years old
 B to live less than five miles from the city centre
 C phone any time before Saturday
- 13 How can people get information about the theatre group?**
 A go to the theatre
 B meet the secretary of the group in Saint Paul's School
 C call the secretary of the group

- 14 What is different about the arrangements at the sports hall this week?**
- A The closing time is later than usual.
 - B It is not possible to hire the football pitch.
 - C All activities must be booked in advance.
- 15 Which of the following is TRUE about the new swimming pool?**
- A It will open next month.
 - B It will be free for one week.
 - C It is bigger than the old one.
- 16 What does the speaker say about the rock group *Switch*?**
- A They were all born in Westfield.
 - B They all live in Westfield.
 - C They are doing two concerts in Westfield.

TEST 24

Task 1

Listen to the speakers. For questions (1 - 6) choose the correct answer (A, B or C). Write your answers on the separate answer sheet. You will listen to each recording twice.

1 What time will the writer arrive at the bookshop?

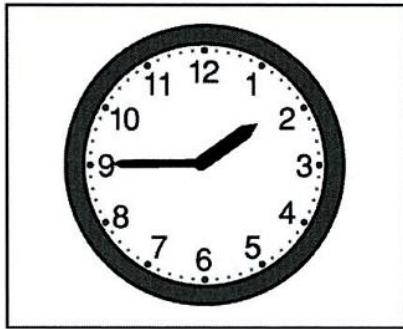

A

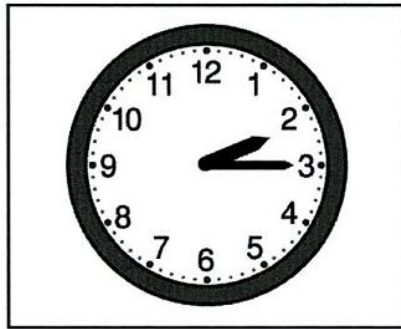

B

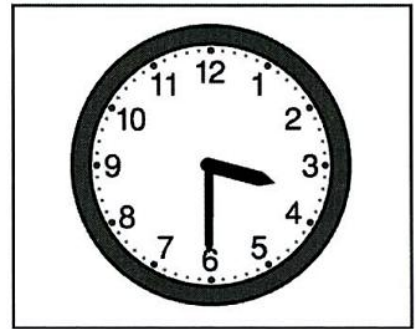

C

2 How did the woman spend her last holiday?



A



B

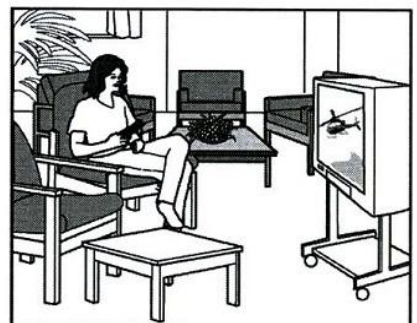

C

3 How much will the girl's ticket cost?



A



B



C

4 What is the television programme about?

- A wildlife in Africa
- B wildlife on the South Pole
- C a voyage to the South Pole

5 What is the subject of James Wilson's book?

- A cookery
- B photography
- C computers

6 Where is the motorcycle race going to finish?

- A on the top of the hill
- B outside the stadium
- C in front of the town hall

Task 2

Listen to the text. For statements (7-11) choose T if the statement is true, F if it is false according to the text. Write your answers on the separate answer sheet. You will listen to the text twice.

- | | T | F |
|---|--------------------------|--------------------------|
| 7 Ian is going to visit relatives who live in Africa. | <input type="checkbox"/> | <input type="checkbox"/> |
| 8 Zoe believes Namibia is a good place to visit. | <input type="checkbox"/> | <input type="checkbox"/> |
| 9 Ian's parents insist he must go on holiday with them. | <input type="checkbox"/> | <input type="checkbox"/> |
| 10 Zoe's father is unemployed. | <input type="checkbox"/> | <input type="checkbox"/> |
| 11 Zoe's mother dislikes flying. | <input type="checkbox"/> | <input type="checkbox"/> |

Task 3

Listen to the text. For questions (12-16) choose the correct answer (A, B or C). Write your answers on the separate answer sheet. You will listen to the text twice.

12 What is TRUE about the speaker's school days?

- A Girls were taught separately from boys.
- B Girls could do carpentry if they wanted to.
- C Gils were not allowed to do carpentry.

13 How long did it take the woman to make her chest of drawers?

- A eighteen months
- B six months
- C two months

14 Where did she first plan to put the chest of drawers?

- A in the sitting room.
- B in the bedroom.
- C in the hall.

15 According to the speaker, which of the following is NOT TRUE about electric tools?

- A They are as useful as hand tools.
- B They require less physical effort.
- C Their speed helps you control the process.

16 What does she suggest that the class should do first?

- A choose who they will work with
- B decide what they need for one job
- C discuss what they should do

Name _____

Test _____

	A	B	C
1			
2			
3			
4			
5			
6			

	T	F
7		
8		
9		
10		
11		

	A	B	C
12			
13			
14			
15			
16			

-

Name _____

Test _____

	A	B	C
1			
2			
3			
4			
5			
6			

	T	F
7		
8		
9		
10		
11		

	A	B	C
12			
13			
14			
15			
16			

Name _____

Test _____

	A	B	C
1			
2			
3			
4			
5			
6			

	T	F
7		
8		
9		
10		
11		

	A	B	C
12			
13			
14			
15			
16			

Name _____

Test _____

	A	B	C
1			
2			
3			
4			
5			
6			

	T	F
7		
8		
9		
10		
11		

	A	B	C
12			
13			
14			
15			
16			



Name _____

Test _____

	A	B	C
1			
2			
3			
4			
5			
6			

	T	F
7		
8		
9		
10		
11		

	A	B	C
12			
13			
14			
15			
16			



Name _____

Test _____

	A	B	C
1			
2			
3			
4			
5			
6			

	T	F
7		
8		
9		
10		
11		

	A	B	C
12			
13			
14			
15			
16			

Name _____

Test _____

	A	B	C
1			
2			
3			
4			
5			
6			

	T	F
7		
8		
9		
10		
11		

	A	B	C
12			
13			
14			
15			
16			

Name _____

Test _____

	A	B	C
1			
2			
3			
4			
5			
6			

	T	F
7		
8		
9		
10		
11		

	A	B	C
12			
13			
14			
15			
16			

Name _____

Test _____

	A	B	C
1			
2			
3			
4			
5			
6			

	T	F
7		
8		
9		
10		
11		

	A	B	C
12			
13			
14			
15			
16			

Name _____

Test _____

	A	B	C
1			
2			
3			
4			
5			
6			

	T	F
7		
8		
9		
10		
11		

	A	B	C
12			
13			
14			
15			
16			

Name _____

Test _____

	A	B	C
1			
2			
3			
4			
5			
6			

	T	F
7		
8		
9		
10		
11		

	A	B	C
12			
13			
14			
15			
16			

Name _____

Test _____

	A	B	C
1			
2			
3			
4			
5			
6			

	T	F
7		
8		
9		
10		
11		

	A	B	C
12			
13			
14			
15			
16			

Name _____

Test _____

	A	B	C
1			
2			
3			
4			
5			
6			

	T	F
7		
8		
9		
10		
11		

	A	B	C
12			
13			
14			
15			
16			

Name _____

Test _____

	A	B	C
1			
2			
3			
4			
5			
6			

	T	F
7		
8		
9		
10		
11		

	A	B	C
12			
13			
14			
15			
16			

Name _____

Test _____

	A	B	C
1			
2			
3			
4			
5			
6			

	T	F
7		
8		
9		
10		
11		

	A	B	C
12			
13			
14			
15			
16			

Name _____

Test _____

	A	B	C
1			
2			
3			
4			
5			
6			

	T	F
7		
8		
9		
10		
11		

	A	B	C
12			
13			
14			
15			
16			

Name _____

Test _____

	A	B	C
1			
2			
3			
4			
5			
6			

	T	F
7		
8		
9		
10		
11		

	A	B	C
12			
13			
14			
15			
16			

Name _____

Test _____

	A	B	C
1			
2			
3			
4			
5			
6			

	T	F
7		
8		
9		
10		
11		

	A	B	C
12			
13			
14			
15			
16			

Name _____

Test _____

	A	B	C
1			
2			
3			
4			
5			
6			

	T	F
7		
8		
9		
10		
11		

	A	B	C
12			
13			
14			
15			
16			

Name _____

Test _____

	A	B	C
1			
2			
3			
4			
5			
6			

	T	F
7		
8		
9		
10		
11		

	A	B	C
12			
13			
14			
15			
16			

Name _____

Test _____

	A	B	C
1			
2			
3			
4			
5			
6			

	T	F
7		
8		
9		
10		
11		

	A	B	C
12			
13			
14			
15			
16			

Name _____

Test _____

	A	B	C
1			
2			
3			
4			
5			
6			

	T	F
7		
8		
9		
10		
11		

	A	B	C
12			
13			
14			
15			
16			

Name _____

Test _____

	A	B	C
1			
2			
3			
4			
5			
6			

	T	F
7		
8		
9		
10		
11		

	A	B	C
12			
13			
14			
15			
16			

Name _____

Test _____

	A	B	C
1			
2			
3			
4			
5			
6			

	T	F
7		
8		
9		
10		
11		

	A	B	C
12			
13			
14			
15			
16			

References

- 1) Cambridge English: Preliminary 7. With Answers. Official Examination Papers from University of Cambridge ESOL Examinations. (2013). Cambridge University Press Publishers, p. 171.
- 2) Cambridge Preliminary English Test 2. With Answers. Examination Papers from University of Cambridge ESOL Examinations: English for Speakers of Other Languages. (2003). Cambridge University Press Publishers, p. 172.
- 3) Cambridge Preliminary English Test 3. With Answers. Examination Papers from University of Cambridge ESOL Examinations: English for Speakers of Other Languages. (2007). Cambridge University Press Publishers, p. 143.
- 4) Cambridge Preliminary English Test 4. With Answers. Examination Papers from University of Cambridge ESOL Examinations: English for Speakers of Other Languages. (2007). Cambridge University Press Publishers, p. 150.
- 5) Cambridge Preliminary English Test 5. With Answers. Examination Papers from University of Cambridge ESOL Examinations. (2008). Cambridge University Press Publishers, p. 159.
- 6) Cambridge Preliminary English Test 6. With Answers. Examination Papers from University of Cambridge ESOL Examinations.(2010) Cambridge University Press, p. 158.
- 7) Hashemi, L., Thomas, B. (2006). PET. Preliminary English Test. Practice Tests Plus 1. Pearson Education Limited Publishers, p. 219.
- 8) Preliminary English Test. Handbook. (2003). UCLES Publishers, p. 69.

Навчальне видання

**ПРАКТИКУМ ДЛЯ ПІДГОТОВКИ
ДО ЗОВНІШНЬОГО
НЕЗАЛЕЖНОГО ОЦІНЮВАННЯ
З АНГЛІЙСЬКОЇ МОВИ
АУДІЮВАННЯ**

Для слухачів факультету довузівської підготовки

Упорядник КАРПЕНКО Олена Валентинівна

В авторській редакції
Комп'ютерній набір: Карпенко О.В.

Підписано до друку 08.10.2018. Формат 60×84/16.
Папір офсетний. Гарнітура «Таймс».
Ум. друк. арк. 11,62 Обл.-вид. арк. 6,5
Тираж 100 пр.

Видавництво
Народної української академії
Свідоцтво № 1153 від 16.12.2002.

Надруковано у видавництві
Народної української академії

Україна, 61000, Харків, МСП, вул. Лермонтовська, 27.